



Parts Manual - 26475
Revision R

Fill in appropriate fields that apply to this machine

Machine S/N: _____

Hose S/N: _____

Wand S/N: _____

Pump S/N: _____

Engine S/N: _____

Revisions

Rev.	Description	Date
H	Added section 2.4. Updated wand figure in Ch. 5, and section 9.15. Updated part numbers in section 9.15. Updated chapter 3. Updated section 5.11. Added section 6.21. Updated section 9.9 with more part numbers. Changed item 1 to 42070 in section 9.6. Removed a section from Ch. 6 on an old burner flame retainer.	12/17/18
J	ENG-052: Updated section 9.19 Diesel Fuel Line Schematic Fig. 9-22 and the associated parts list to reflect the separate fuel supply for the burner. ENG-601: Updated section 9.16 DIN plug locations in Fig. 9-18 and Fig. 9-19. Update Section 10.0 with newest tool names.	2/6/19
K	Update hydraulic pressure relief valve settings Shown in figure 8.6. Pump pressure is 1000 psi; was 1500 psi. Agitator pressure is 1500 psi; was 1000 psi. Hot oil pump pressure is 800 psi; was 500 psi. Update part number of fuel tank in parts list 9.2, is: 47060N; was 46250	4/19
L	Added Towing with Burner On Warning Section 2.5, Added Section 9.16	5/15/19
M	Part number correction to item 10 Figure 9.20 Parts Table: Is 40311, was 22029. Part number correction to item 11 Figure 9.20 Parts Table: Is 40311, was 22029. Figure 9.6 parts list: added PN 47658N and reduced qty of PN 41404 to 2. Updated Figure 9.6. Added part number for Flow Control Cartridge Valve, Figure 9-18. Added information for changing heat transfer oil, Section 6.19, table 6-7, Fig. 6-3.	5/11/20
N	Change control box and engine to direct engine controls for 46400SB and 46400EB configurations.	7/17/20
P	Added FMCSA compliant diesel fuel tank and vent to Fig. 9-2 parts list and Fig. 9-3. Replaced fitting 47497N with fitting 26782 for burner return line in Fig. 9-22 and parts list	2/11/21
Q	Updated tire size in Table 4-1. Added burner fuel filter change in Table 6-1. Updated Figure 9-3 to include new safety & work light kit.	11/11/21
R	Deleted Section 6.11, Replacing Heat Transfer Oil. Updated Section 6.18, Changing Heat Transfer Oil. Added graphics and leaders for clarity.	5/15/23



**EZ1500 Series II Melter - Electric Hose
PN 46400EB**



**EZ1500 Series II Melter - Standard Hose
PN 46400SB**

Table of Contents

1.0 About This Manual 1-1

 1.1 How to use this manual: 1-1

2.0 Safety Precautions..... 2-1

 2.1 General Safety 2-1

 2.2 Personal Safety 2-1

 2.3 Equipment or Operational Safety..... 2-1

 2.4 California Proposition 65 2-2

 2.4.1 All Crafcoc, Inc. Equipment 2-2

 2.4.2 All Crafcoc, Inc. Equipment using a diesel engine 2-2

 2.5 Towing or Driving for Transporting with Burner On 2-2

 2.6 Safety Symbols and Notices..... 2-3

3.0 Limited Warranty..... 3-1

 3.1 Warranty Claim Instructions..... 3-2

4.0 Machine Specifications 4-1

5.0 Operating Instructions 5-1

 5.1 Preparing the Machine for Start Up 5-1

 5.2 Machine Start Up for Electric Hose..... 5-3

 5.3 Altitude Compensation System..... 5-6

 5.4 About the Heated Hose, Wand, Valve, and Tip Guard..... 5-6

 5.5 Electric Hose Care and Cautions..... 5-7

 5.6 Storing the Electric Hose for Transport..... 5-7

 5.7 Machine Start Up for Standard Hose 5-8

 5.8 Loading Material into the Sealant Tank 5-10

 5.8.1 Material Tank Depth Chart..... 5-11

 5.9 Dispensing the Material 5-12

 5.10 Shutting Down and Cleaning Out the Machine 5-13

 5.11 Overnight Heater Use..... 5-15

 5.12 Storing the Machine 5-16

6.0 Maintenance Instructions 6-1

 6.1 Engine..... 6-1

 6.2 Hydraulic System 6-1

 6.3 Heat Transfer Oil..... 6-1

 6.4 Wheel Bearing..... 6-1

 6.5 Material Sensor Tube 6-1

Table of Contents

6.6 Pump Packing Adjustment and Replacement	6-1
6.7 Lug Nuts	6-1
6.8 Brakes	6-2
6.9 Tongue Jack	6-2
6.10 Temperature Control Calibration	6-3
6.11 Maintenance Chart	6-4
6.12 Service Instructions	6-5
6.13 General Maintenance Parts	6-5
6.14 Recommended Spare Parts	6-6
6.15 Recommended Fluids and Lubricants	6-6
6.16 Applicable Brands of Heat Transfer Oil	6-7
6.17 Typical Heat Transfer Oil Specifications	6-7
6.18 Changing the Heat Transfer Oil	6-8
6.19 Cleaning Material Tank and Sensor Area	6-10
6.20 Cleaning the Melter	6-10
6.21 Material Pump Replacement	6-11
6.22 Wand Repair Instructions	6-13
6.22.1 Cable Replacement	6-13
6.22.2 Switch Replacement	6-13
6.22.3 Terminal Block Replacement	6-13
6.22.4 Wand Handle Replacement	6-14
6.23 Burner Fuel Filter Replacement	6-17
7.0 How to Use a Multimeter	7-1
7.1 Checking DC Voltage with a Multimeter	7-1
7.2 Checking AC Voltage with Multimeter	7-1
7.3 Checking Resistance (Ohms)	7-1
7.4 Checking Amperage	7-2
8.0 Burner Troubleshooting	8-1
8.1 Sealant is Heating Slowly	8-12
8.2 Agitator Troubleshooting	8-13
8.2.1 Symptom: Mixer Does Not Rotate	8-13
8.2.2 Mixer Electrical Troubleshooting	8-14
8.2.3 Mixer Hydraulic Troubleshooting	8-18
8.3 Hose Troubleshooting	8-21
8.3.1 Symptom: Passenger Side Hose Does Not Heat	8-21

Table of Contents

8.3.2 Symptom: Trigger is not Working.....	8-26
8.3.3 RTD Sensor Ohms vs. Temperature	8-27
8.4 Pump Troubleshooting	8-29
8.4.1 Symptom: Material Does Not Dispense When the Pump is Activated.....	8-29
8.4.2 Pump Hydraulic Troubleshooting.....	8-35
9.0 About the Illustrated Parts List	9-1
9.1 Ordering Crafcoc Parts	9-1
9.2 EZ1500 Series II Melter.....	9-2
9.3 EZ1500 Series II Melter Options.....	9-6
9.4 Optional Engine Cover	9-8
9.5 Tank Assembly.....	9-9
9.6 Plumbing	9-10
9.7 Control Box Assembly 47202 – 46400EB - Electric Hose.....	9-12
9.8 Control Box Assembly 47260N – 46400SB - Standard Hose.....	9-16
9.9 Engine Assembly.....	9-20
9.10 Hydraulic Control Valve Assembly.....	9-22
9.11 Hydraulic Compressor Valve Assembly	9-23
9.12 Diesel Burner Assembly	9-24
9.13 Material Pump Assembly.....	9-27
9.14 Hot Oil Pump and Motor Assembly.....	9-28
9.15 Wand Assembly	9-30
9.16 Material Flow Control Assembly	9-31
9.17 Hydraulic Diagram.....	9-32
9.18 Electrical Schematic – Electric Hose	9-36
9.19 Electrical Schematic – Standard Hose.....	9-38
9.20 Diesel Fuel Line Schematic	9-40
9.21 High Velocity Heat Lance	9-42
10.0 Tools and Accessories.....	10-1

List of Figures

Fig. 5-1 Dipstick	5-2
Fig. 5-2 Hydraulic Fluid Level and Temp. Gauge	5-2
Fig. 5-3 Heat Transfer Oil Dip Stick.....	5-2
Fig. 6-1 Lug bolt Tightening Sequence.....	6-2
Fig. 6-2 Temperature Control Calibration	6-3
Fig. 6-3 Heat Transfer Oil Drain and Fill Ports.....	6-9
Fig. 6-4 Center Heating Tower Diagram.....	6-9
Fig. 6-5 Material Pump Replacement.....	6-12
Fig. 7-1 Standard Multimeter.....	7-2
Fig. 7-2 Clamp-On Amp Meter/Multimeter.....	7-3
Fig. 7-3 Clamp – On Amp Meter/Multimeter	7-3
Fig. 8-1 Diesel Burner Schematic.....	8-7
Fig. 8-2 Diesel Burner Electrode Adjustment.....	8-11
Fig. 8-3 Diesel Burner Air Settings	8-11
Fig. 8-4 Checking Din Plug Voltage.....	8-16
Fig. 8-5 Mixer Circuit.....	8-17
Fig. 8-6 Hydraulic Valve Pressure Setting	8-19
Fig. 8-7 Din Plug Layout.....	8-20
Fig. 8-8 Junction Box Voltage Testing.....	8-23
Fig. 8-9 Hose Circuit Schematic.....	8-24
Fig. 8-10 Junction Box Schematic.....	8-25
Fig. 8-11 Pump Circuit Schematic.....	8-34
Fig. 9-1 EZ1500 Series II Melter	9-2
Fig. 9-2 EZ1500 Series II Melter	9-4
Fig. 9-3 EZ1500 Series II Melter Options	9-6
Fig. 9-4 Optional Engine Cover	9-8
Fig. 9-5 Tank Detail.....	9-9
Fig. 9-6 Plumbing.....	9-10
Fig. 9-7 Control Box Assembly 47255N– 46400EB.....	9-12
Fig. 9-8 Control Box Assembly 47255N– 46400EB.....	9-14
Fig. 9-9 Control Box Assembly 47260N– 46400SB.....	9-16

List of Figures

Fig. 9-10 Control Box Assembly 47260N– 46400SB.....	9-18
Fig. 9-11 Engine Assembly – 46400EB, 46400SB	9-20
Fig. 9-12 Hydraulic Control Valve	9-22
Fig. 9-13 Compressor Valve	9-23
Fig. 9-14 Diesel Burner Assembly.....	9-24
Fig. 9-15 Material Pump Assembly	9-27
Fig. 9-16 Hot Oil Pump and Motor Assembly	9-28
Fig. 9-17 Wand Assembly.....	9-30
Fig. 9-18 Material Flow Control Assembly.....	9-31
Fig. 9-19 Hydraulic Diagram 46400EB, 46400SB	9-32
Fig. 9-20 Hydraulic Diagram – 46400EB, 46400SB	9-34
Fig. 9-21 Electrical Schematic 46400EB	9-36
Fig. 9-22 Electrical Schematic 46400SB	9-38
Fig. 9-23 Diesel Fuel Line Schematic.....	9-40
Fig. 9-24 Hot Air Lance (Option)	9-42

List of Tables

Table 2-1 Safety Symbols and Notices	2-3
Table 2-2 Safety Symbols and Notices (continued).....	2-4
Table 4-1 Machine Specifications.....	4-1
Table 5-1 Preparing the Machine for Start Up	5-1
Table 5-2 Starting the Burner for Electric Hose	5-3
Table 5-3 Electric Hose Care	5-7
Table 5-4 Hose for Transport Instructions	5-7
Table 5-5 Starting the Burner for Standard Hose	5-8
Table 5-6 Loading Material into the Sealant Tank	5-10
Table 5-7 Material Tank Depth Chart	5-11
Table 5-8 Dispensing the Material – Electric Hose	5-12
Table 5-9 Dispensing the Material – Standard Hose	5-13
Table 5-10 Shutting Down with an Electric Hose.....	5-14
Table 5-11 Shutting Down with a Standard Hose.....	5-14
Table 5-12 Overnight Heater Use.....	5-15
Table 6-1 Maintenance Chart.....	6-4
Table 6-2 Service Instructions.....	6-5
Table 6-3 General Maintenance Parts.....	6-5
Table 6-4 Recommended Spare Parts	6-6
Table 6-5 Recommended Fluids and Lubricants	6-6
Table 6-6 Applicable Brand of Heat Transfer Oil	6-7
Table 6-7 Changing the Heat Transfer Oil.....	6-8
Table 6-8 Material Pump Replacement	6-11
Table 6-9 Burner Fuel Filter Replacement.....	6-17
Table 8-1 Basic Visual Burner Troubleshooting.....	8-1
Table 8-2 Basic Visual Burner Troubleshooting (continued)	8-2
Table 8-3 Burner Electrical Troubleshooting	8-3
Table 8-4 Burner Electrical Trouble shooting (continued)	8-4
Table 8-5 Burner Electrical Trouble shooting (continued)	8-5
Table 8-6 Burner Electrical Troubleshooting (continued).....	8-6
Table 8-7 Smoke Coming Out of Exhaust Stack	8-8

List of Tables

Table 8-8 Burner Lights but Shuts Down After 15 Seconds	8-8
Table 8-9 Testing the DC Controller.....	8-9
Table 8-10 Burner Fuel Solenoid Test	8-9
Table 8-11 Burner Ignition Coil Test.....	8-10
Table 8-12 Bleeding the Diesel Burner	8-10
Table 8-13 Sealant is Heating Slowly.....	8-12
Table 8-14 Basic Visual Mixer Troubleshooting	8-13
Table 8-15 Mixer Electrical Troubleshooting	8-14
Table 8-16 Mixer Electrical Troubleshooting (continued).....	8-15
Table 8-17 Mixer Hydraulic Troubleshooting.....	8-18
Table 8-18 Basic Visual Hose Troubleshooting.....	8-21
Table 8-19 Hose Electrical Troubleshooting.....	8-21
Table 8-20 Hose Electrical Troubleshooting (continued).....	8-22
Table 8-21 Electrical Troubleshooting (continued)	8-23
Table 8-22 Trigger is Not Working	8-26
Table 8-23 RTD Sensor Ohms vs. Temperature.....	8-27
Table 8-24 RTD Sensor Ohms vs. Temperature (continued)	8-28
Table 8-25 Basic Visual Pump Troubleshooting.....	8-29
Table 8-26 Pump Electrical Troubleshooting.....	8-30
Table 8-27 Pump Electrical Troubleshooting (continued)	8-31
Table 8-28 Pump Electrical Troubleshooting (continued)	8-32
Table 8-29 Pump Electrical Troubleshooting (continued)	8-33
Table 8-30 Hydraulic Troubleshooting	8-35

Chapter 1 Introduction

1.0 About This Manual

This manual is supplied with each new CrafcO EZ Series II 1500 Diesel Melter. The manual assists your machine operators in the proper use of the melter applicator and provides information about the machine's mechanical functions.

Your CrafcO EZ Series II 1500 Diesel Melter is specially made to give excellent service and save maintenance expense. However, as with all specially engineered equipment, you get best results at minimum cost if you:

Operate your machine as instructed in this manual.

Maintain your machine regularly as stated in this manual.

1.1 How to use this manual:

This manual is formatted to start each new chapter on the right page. There may be a blank page on the left page if the previous chapter ends on the right page.

If you are viewing this in a digital format (PDF) the following features are available:

1. The Table of Contents, List of Tables, and List of Figures are all hyperlinks, when mouse is left clicked on section, table, or figure you will be sent to that page.
2. The blue highlighted text throughout the manual is a hyperlink, when mouse is left clicked you will be sent to that page, table, or figure.
3. The panel to the left in the PDF is a bookmarks panel, if you left mouse click on any section/heading in the bookmarks panel you will be sent to that page.

Chapter 2 Safety

2.0 Safety Precautions

For more in-depth safety information, please see Safety Manual (PN 26221) which comes with the machine. Or contact your nearest authorized Crafco Distributor at crafco.com/Distributors.

2.1 General Safety

- Crafco, Inc. assumes no liability for an accident or injury incurred through improper use of the machine.
- Read this manual thoroughly before operating the machine.
- Obey all CAUTION and WARNING signs posted on the machine.
- Make sure an operator fully knows how to operate the machine before using the machine.

2.2 Personal Safety

- The high operating temperatures of this machine and the sealant it contains requires that protective clothing, gloves, hard-soled shoes, and safety glasses or a face shield be worn at all times by operators of the machine.
- Prevent water from going into any part of the machine. If there is indication of water in the heat transfer oil system, warm heating oil to 250-300°F for 2 to 3 hours.
- Bodily contact with hot sealant or heat transfer oil can cause severe burns.
- If the mixer is not stopped before adding solid material, hot material can get on an operator's body and cause severe burns.
- Keep hands, feet, and clothing away from all moving parts.

2.3 Equipment or Operational Safety

- Do not operate the machine in buildings or work areas that do not have sufficient airflow.
- Shut-down the burner and the engine before refilling the fuel tank.
- Make sure mixer stops before adding solid material to the sealant tank. Lift the lid, place the material on the lid and close the lid. The mixer should restart automatically.
- Always keep a correctly maintained fire extinguisher near the machine and know how to use it.
- DO NOT heat transfer oil to a temperature of more than 525°F.
- DO NOT put too much heat transfer oil in the reservoir. The expansion of oil while it heats up can cause overflow. With the machine on level ground, check the oil each day before starting the burner. Add oil to the top mark on the dipstick if required (at 70°F). Use only recommended heat transfer oil. Change the oil after 500 hours of machine operation, or one year, whichever comes first.
- Follow the operating instructions for starting and shutting down the burner. Instructions are mounted on the control box on the machine.
- Calibrate the temperature control operation after each 50 hours of machine operation. Refer to section [6.10 Temperature Control Calibration](#).
- Replace any hoses which show signs of wear, fraying or splitting.
- Make sure all fittings and joints are tight and do not leak each time the machine is used.
- Do not leave the machine unattended while the burner is lit.
- Tighten all bolts and screws every 100 hours of machine operation.

Chapter 2 Safety

2.4 California Proposition 65

The state of California currently maintains a list of chemicals that can cause cancer, birth defects or other reproductive harm. Your CrafcO, Inc. equipment comes with the following warnings:

2.4.1 All CrafcO, Inc. Equipment

 **WARNING:** Cancer and Reproductive Harm - www.P65Warnings.ca.gov
26471N

2.4.2 All CrafcO, Inc. Equipment using a diesel engine

 **WARNING:** Breathing diesel engine exhaust exposes you to chemicals known to the State of California to cause cancer and birth defects or other reproductive harm.

- Always start and operate the engine in a well-ventilated area.
- If in an enclosed area, vent the exhaust to the outside.
- Do not modify or tamper with the exhaust system.
- Do not idle the engine except as necessary.

For more information go to www.P65warnings.ca.gov/diesel.

26307

2.5 Towing or Driving for Transporting with Burner On

The burner in your CrafcO machine is designed for operation only while the unit is parked or towed at slow speeds while applying sealant at a jobsite. When driving or towing this machine for transport, the burner shall be turned off. Operating the burner when transporting the machine is a violation of The Code of Federal Regulations, CFR Title 49, Part 392, Subpart G, 392.67 and may cause damage to the burner and/or machine.

CAUTION





The burner in your CrafcO machine is designed for operation only while the unit is parked or towed at slow speeds while applying sealant at a jobsite. **When driving or towing this machine for transport, the burner shall be turned off.**

Chapter 2 Safety

2.6 Safety Symbols and Notices





Important safety symbols and notices are marked on the machine and in this manual. Failure to comply could result in equipment damage, operational malfunction, serious injury, or death. Please read and comply with all symbols and notices. The table below includes the most commonly used symbols and notices.

Table 2-1 Safety Symbols and Notices

Symbol	Item	Remarks
WARNING	Warning	Refers to possible bodily injury or death.
CAUTION	Caution	Refers to possible equipment damage or operational malfunction.
	Severe Burn Hazard	Hot material can cause severe burns.
	Protective Shoes	Wear hard-soled work shoes.
	Protective Gloves	Wear heat resistant gloves.
	Protective Face or Eye Wear	Wear face shield or safety glasses.
	Body Crush Hazard	Do not stand between trailer and hitch when hooking melter to truck.

Chapter 2 Safety

Table 2-2 Safety Symbols and Notices (continued)

Symbol	Item	Remark
	Crush Hazard	Keep feet and legs clear.
	Pinch Hazard	Keep hands and feet clear.
	Exhaust Hazard	Avoid breathing engine exhaust.
	Read Manual	Read and understand operator and safety manuals before operating machine.

Chapter 3 Warranty Information

3.0 Limited Warranty

Crafco, Inc., through Crafco or one of its affiliated distributors, will replace for the original purchaser free of charge any parts found upon examination by the factory at Chandler, Arizona, to be defective in material or workmanship. This warranty is for a period **two years** from invoice date, but excludes engine or components, tires, and battery as these items are subject to warranties issued by their manufacturers.

Crafco, Inc. shall not be liable for parts that have been damaged by accident, alteration, abuse, improper lubrication/maintenance, normal wear, or other cause beyond our control.

The warranty provided herein extends only to the repair and/or replacement of those components on the equipment covered above and does not cover labor costs. The warranty does not extend to incidental or consequential damages incurred as a result of any defect covered by this warranty.

All transportation and labor costs incurred by the purchaser in submitting or repairing covered components must be borne by the purchaser. Crafco, Inc. specifically disavows any other representation, warranty, or liability related to the condition or use of the product

CAUTION

Use of replacement parts other than genuine Crafco parts may impair the safety or reliability of your equipment and nullifies any warranty.

Chapter 3 Warranty Information

3.1 Warranty Claim Instructions

Crafco, Inc. warrants parts and machinery purchased through Crafco or one of its affiliated distributors for two years from the invoice date. Wear items are not covered under the Crafco, Inc. limited warranty. A wear item is defined as but not limited to: material pumps, sealing tips, tires, etc.

If parts fail to function within two years of invoice date, a return authorization number (RA) must be obtained. If the part was purchased through Crafco, Inc., please contact Crafco returns department at [Returns@Crafco.com](mailto>Returns@Crafco.com) for an RA number or if purchased through a Crafco distributor please contact your distributor.

Note: if the part has a serial number associated with it, for example; a machine or electric hose or wand, this must be furnished when requesting the RA number. The customer will be emailed or faxed an RA form with all instructions to return the item to Crafco, Inc. See example. If the part is found to be within the two year warranty period and has not been abused or modified, a credit will be issued to the customer's account or credit card. The customer may request the part be replaced instead of a credit, if desired.

Note: All engine warranties are covered through the engine manufacturer. If you need information for a distributor in your area please contact us and we will direct you to the closest engine distributor.

All parts returned are tested and evaluated. If the part has been modified in any way without prior consent from a Crafco, Inc. representative, warranty is void.

Please follow the instructions stated below when calling in a Warranty Claim. Failure to follow these procedures may be cause to void the warranty.

Call your local Crafco Distributor. If you do not know who your local distributor is, call a Crafco Customer Service Representative, (Toll Free 1-800-528-8242) for name, location and telephone number.

On contacting the distributor, be prepared to identify the serial number, model number, engine number, engine manufacturer, and the date of purchase if available.

Should the cause of the malfunction be a defective part, the Distributor will advise you of the procedure to follow for a replacement.

The warranty is valid only for parts, which have been supplied or recommended by Crafco, Inc.

If you have any additional questions regarding warranty repairs and parts, please do not hesitate to call toll free 1-800-528-8242.

For Warranty:
Crafco, Inc.
25527 South Arizona Avenue, Chandler, AZ
85248
Phone: (480) 655-8333 or (800) 528-8242
Fax: (480) 655-1712

For all other inquires:
Crafco, Inc.
6165 W. Detroit Street
Chandler, AZ 85226
Phone: (602) 276-0406 or (800) 528-8242
Fax: (480) 961-0513
CustomerService@crafco.com

Chapter 4 Machine Specifications

4.0 Machine Specifications

Table 4-1 Machine Specifications

Specification	PN 46400EB PN 46400SB
Vat Capacity	396 gallons
Melt Capacity	2800 lbs. per hour
Heat Transfer Oil Required	45.0 gallons at 70°F
Tank Construction	Double boiler type
Tank Opening Size	One 14" x 18", One 16" x 24"
Maximum Heat Input	420,000 BTUs
Burner and Temperature Control	Diesel-forced air thermostatic control
Engine Isuzu Diesel	Three cylinder Model 3CH1 – 21.2 BHP @ 3000 RPM
Drive Mechanism	All hydraulic with infinite speed forward and reverse on material pump. Fixed speed agitator.
Mixer	Full sweep mixer with 2 horizontal paddles, vertical risers
Axle Capacity	Dual 6,000 lbs.
Tires	ST235/80R16 Load Range E
Dry Weight Approximately	6,184 lbs.
Diesel Tank Capacity	30 Gallons
Hydraulic Tank Capacity	26 Gallons

Chapter 5 Operating Instructions

5.0 Operating Instructions

The Crafco EZ 1500 Series II was developed to melt Crafco sealants. However, it works well with most road asphalt and federal specification crack or joint sealants.

Note: DO NOT attempt to operate the machine without using these and all other instructions.

5.1 Preparing the Machine for Start Up

Table 5-1 Preparing the Machine for Start Up

Step	Action
1	Fill the engine fuel tank with diesel fuel. Note: Use No. 1 Diesel fuel in cold weather and No. 2 Diesel fuel in warm weather
2	Check the oil level in the engine crankcase. (Refer to the manufacturer's instruction for the engine.)
3	Check the hydraulic fluid level while at a temperature of 70°F. Add fluid if necessary. See Fig. 5-1 Dipstick
4	With the machine on level surface, check the heat transfer oil level while at a temperature of 70°F. There are two other full marks representing 0°F (-17.8°C) and 150°F and (65.6°C). See Fig. 5-1 Dipstick . The oil level changes with temperature due to expansion and contraction. DO NOT overfill or spillage may occur when the oil is heated and expands. See Fig. 5-3 Heat Transfer Oil Dip Stick
5	Make sure all toggle switches are turned "OFF" and all temperature control dials are set to their minimum settings.
6	Check the oil level in the air compressor if this machine is so equipped.
WARNING	
	<p>The safe operation of this machine is the operator's responsibility.</p> <p>Use extreme care when operating this machine; safety is the result of being careful and paying attention to details. Remember the diesel flame is approximately 2,200°F. Some exposed parts of the machine reach 500°F, the sealant 400°F, and the hydraulic fluid 180°F.</p> <p>Always put on protective clothing, gloves, hard-soled shoes, and safety glasses or a face shield. Be sure that all joints and fittings are tight and leak proof. Immediately replace any hose, which shows any signs of wear, fraying, or splitting. Tighten all bolts, nuts, and screws every 100 hours.</p>

Chapter 5 Operating Instructions



Fig. 5-2 Hydraulic Fluid Level and Temp. Gauge

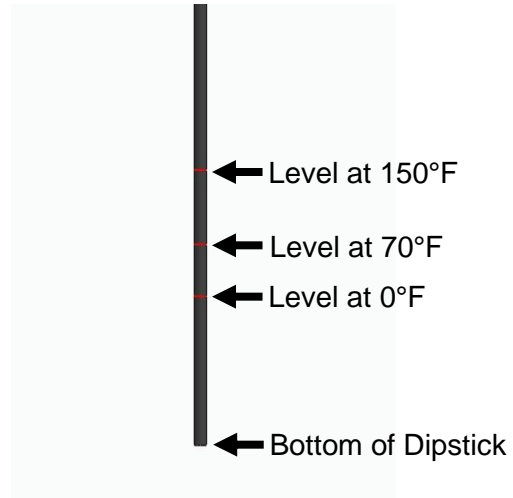

Fig. 5-1 Dipstick

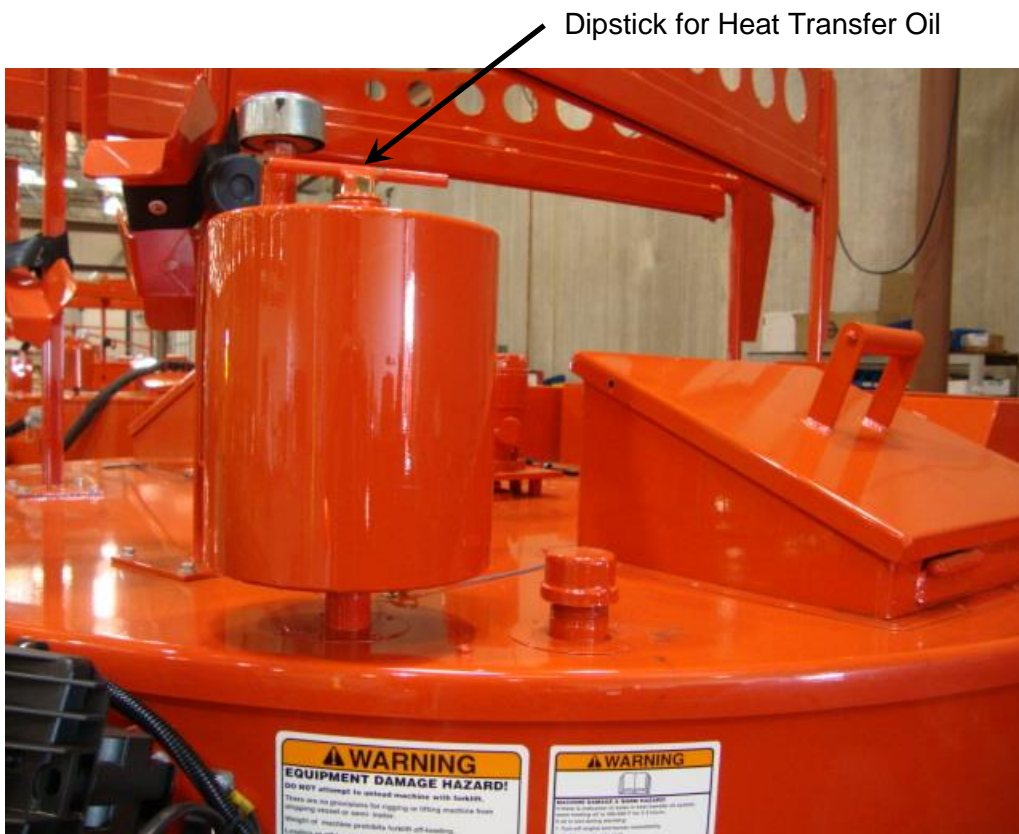

Fig. 5-3 Heat Transfer Oil Dip Stick

Chapter 5 Operating Instructions

5.2 Machine Start Up for Electric Hose

Table 5-2 Starting the Burner for Electric Hose

Step	Action
1	Fully open the exhaust stack cover.
2	<p>Start the engine:</p> <ul style="list-style-type: none"> a) Turn main power key switch to “ON” position. b) Make sure engine controller is in AUTO mode (display should show “Waiting to Start”). If not in AUTO mode, press the AUTO mode button once. c) Press the “RUN” button once. The engine will not crank immediately, it will first run the fuel pump and heat the glow plugs for several seconds, then engine will crank and start. <p>Engine will run at medium idle until the material temperature reaches 275F, at which time, the throttle solenoid on the engine will open the throttle to the running speed which is full throttle. If the engine is started with a warm material tank (over 275F), the engine will run at medium idle for 30 seconds, then the throttle solenoid will open the throttle to the running speed.</p>
3	<p>Turn the “BURNER” toggle switch in the control box to the “ON” position. The red light marked “BURNER” will illuminate indicating that the material and hot oil temperatures are below set point. When the red light goes off this indicates the material or oil temperatures are up to the set point.</p> <p>NOTE: Just because this light is illuminated does not indicate the burner is actually working.</p>
4	<p>Turn “HOSE SELECTOR” switch to “ELECTRIC”.</p> <p>Note: Electric hose will only work if hose selector switch is in the electric hose position.</p>
5	Set the heat transfer oil temperature at 500°F (260°C).
6	Set the material temperature to the manufacturer’s recommended temperature.
	CAUTION
	<p>If the burner does not ignite the first time, turn the “POWER” toggle switch to the “OFF” position. Turn the toggle switch to “ON” again; the burner should ignite. If the burner still does not ignite, refer to 8.0.1 Symptoms: Burner will Not Ignite to determine the malfunction.</p> <p>Important: The solid material in the tank melts first around the walls, bottom, and around the center tower of the tank. The material temperature sensor is located by the wall, therefore, it is possible that at the beginning of the melting process the indicated temperature reaches operating value, but the material between the center tower and the outside wall of the tank is still solid. This is normal, and when the heated hose is ready for operation, most of the material in the tank will be melted and heated to the proper application temperature.</p>

Chapter 5 Operating Instructions

Table 5-2.1 Starting the Burner for Electric Hose (continued)

Step	Action
7	Allow the heat transfer oil to continue to heat.
8	When the material reaches 275°F (135°C), the mixer light will illuminate which indicates the mixer can be engaged by turning the toggle switch at the control panel to “FORWARD” position. If the mixer does not move, allow the material to heat longer. Note: Mixer speed is preset at the factory and cannot be adjusted. The mixer cannot be engaged until the material reaches 275°F (135°C).
CAUTION	
Jamming the mixer can cause the hydraulic oil to overheat and damage the machine.	
9	The hose automatically turns “ON” when the material temperature reaches 275°F (135°C). The red light marked ‘HEATED HOSE” will illuminate when the hose control is calling for heat.
10	Adjust the temperature dial to the manufacturer’s recommended temperature. Note: The hose reaches operating temperature in approximately 30 minutes.
11	After the hose reaches the temperature set point, the light in the control box marked “HEATED HOSE” turns off indicating that the hose is no longer heating.
12	Once the hose reaches 325° F the red light marked “PUMP” will illuminate indicating that the temperature interlock will allow operation of material pump. Important: The hose must reach 325°F before dispensing can take place. If the hose does not dispense when the trigger is activated, allow the material to heat longer. If the hose still does not dispense, shut the machine down, locate and remove the plug in the line. The oven must be at 300°F for 20 minutes before attempting to pump. The oven temperature can be regulated by opening the slide gate to increase temperature or close slide gate to decrease temperature. Slide gate is located on passenger side.
13	Remove hose and wand from transport position and place wand tip in shoebox.
14	When sealant reaches application temperature, open “TANK, RECIRCULATION.
15	Reverse pump for 3-5 minutes by turning the pump toggle switch to “PUMP REVERSE”. When pump turns freely, return switch to “ON ELECTRIC” position.
16	Depress wand trigger to recirculate material back into the tank to get material flowing freely through the pump. Ensure wand tip is fully inserted into the shoebox with the door closed until material is flowing freely.
17	When application of material is desired, open “APPLICATOR VALVE” AND close “RECIRCULATION VALVE”. See Table 5-8 Dispensing the Material – Electric Hose

Chapter 5 Operating Instructions

Table 5-2.2 Starting the Burner for Electric Hose (continued)

Step	Action
	<p>CAUTION</p>
	<p>DO NOT twist or kink the hose. Avoid sharp bends and continuous twisting by maintaining a minimum 10-inch bend radius. DO NOT use a setting on the hose controller of more than 400°F. DO NOT move or bend the hose when cold: it can cause damage to the hose. DO NOT leave the hose cycling for longer than 30 minutes without dispensing material; coking can occur and permanently damage the hose. DO NOT remove the hose from the boom during operation or kinking will occur.</p> <p>Important: It is strongly recommended that the hose be stored in the boom (locked position) when not in use or when in transit. This will prevent twisting or kinking.</p>

Chapter 5 Operating Instructions

5.3 Altitude Compensation System

This unit may be equipped with an Altitude Compensation System. If so, there will be a small boxed housing mounted near the engine mount cross member. The system is automatic during most operating conditions. However, if the machine is taken from above or below an altitude of 2,624 ft. (800 Meters) while the engine is running, the engine will need to be stopped and then restarted. There is a yellow indicator light that illuminates when the machine is above 2,624 ft. (800 Meters) indicating that the system is active.

5.4 About the Heated Hose, Wand, Valve, and Tip Guard

The Heated Hose

The heated hose supplied with the machine is Teflon-lined with steel over braid. It has a heating element, which runs the length of the hose to heat the material within the hose. The hose is covered with high temperature, durable rubber.

The Wand

The wand has an aluminum tube to protect both the wand and the operator. The pistol grip actuator is equipped with an electric switch which, when depressed, sends a signal to actuate the pump. The wand is equipped with a trigger lock to prevent accidental pump actuation when it is not pumping material. The trigger must be in the "LOCKED" position at all times except when intentionally pumping material.

The Valve

The wand has a disposable duckbill valve on the end, which shuts off the flow of material when the pump is turned off and prevents excessive dripping of material. This valve also directs the material into a stream for easy application into the crack. Other sealing tips are available. See [10.0 Tools and Accessories](#) for other sealing tips and options.

Tip Guard

The wand has a Tip Guard installed at the factory only when a duckbill is installed. This Tip Guard is not required when using sealing disk or dripless tip adapter. The purpose of this guard is to prolong the life of the duckbill and to protect the operator in the event of a duckbill failure. Ensure this guard is installed properly before operating equipment. See below.

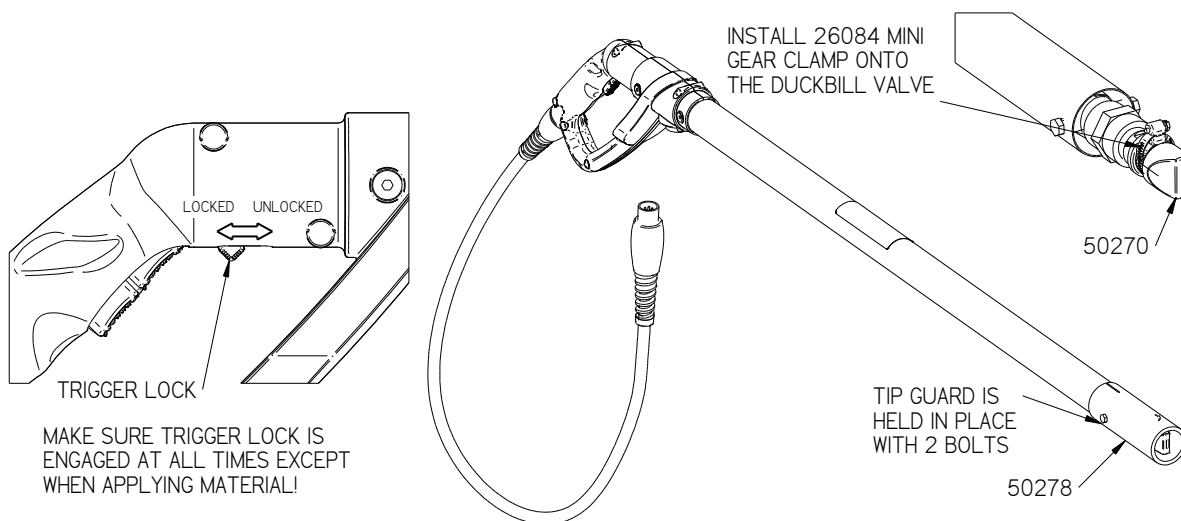

Chapter 5 Operating Instructions

5.5 Electric Hose Care and Cautions

Table 5-3 Electric Hose Care

Step	Action
	CAUTION
	<p>Twisting and kinking of the electric hose (used on BAX, Super Shots, and EZ Series Melters) causes the hose to fail; the electric heating wires are shorted out to the metal hose cover and the hose stops heating.</p> <p>This type of failure is not covered under the CrafcO warranty.</p>
1	Set the hose temperature at 380°F, or manufacturer recommended operating temperature.
2	Allow the hose to be turned “ON” and heating for a minimum of 30 minutes.
3	<p>Make sure the hose swivel between the hose and wand moves freely.</p> <p>Note: Do not twist or bend the hose over sharp edges such as the edge of the frame or tank. CrafcO, Inc. recommends you do not work directly under the boom; this may cause damage to the hose.</p>
4	Follow all machine instructions in this manual.
	CAUTION
	<p>Hose damage occurs if:</p> <ul style="list-style-type: none"> The hose is bent or moved when cold. The hose is twisted or bent at a sharp radius. The hose is moved before being heated a minimum of 30 minutes and set at 380°F. The operator crosses over or under the hose causing the wires between the hose and wand connection to twist or wrap up. The swivel is cold and is not flexible which can cause the hose to twist. The wiring between the hose and the wand is pulled, stressed, or used to support the wand.

5.6 Storing the Electric Hose for Transport

Table 5-4 Hose for Transport Instructions

Step	Action
1	Leave the hose in the boom, swing the boom counterclockwise towards the front of the machine and lock the boom into position with the latch provided.
2	Place the wand in the wand holder and lock the wand into position with the latch provided.

Chapter 5 Operating Instructions

5.7 Machine Start Up for Standard Hose

Table 5-5 Starting the Burner for Standard Hose

Step	Action
1	Fully open the exhaust stack.
2	<p>Start the engine:</p> <ul style="list-style-type: none"> a) Turn main power key switch to “ON” position b) Make sure engine controller is in AUTO mode (display should show “Waiting to Start”). If not in AUTO mode, press the AUTO mode button once. c) Press the “RUN” button once. The engine will not crank immediately, it will first run the fuel pump and heat the glow plugs for several seconds, then engine will crank and start. <p>Engine will run at medium idle until the material temperature reaches 275F, at which time, the throttle solenoid on the engine will open the throttle to the running speed which is full throttle. If the engine is started with a warm material tank (over 275F), the engine will run at medium idle for 30 seconds, then the throttle solenoid will open the throttle to the running speed.</p>
3	<p>Turn the “BURNER” toggle switch in the control box to the “ON” position. The red light marked “BURNER” will illuminate indicating that the material and hot oil temperatures are below set point. When the red light goes off this indicates the material or oil temperatures are up to the set point.</p> <p>NOTE: Just because this light is illuminated does not indicate the burner is actually working.</p>
4	Turn “HOSE SELECTOR” switch to “STANDARD”.
5	Set the heat transfer oil temperature at 450°F (260°C).
6	Set the material temperature to the manufacturer’s recommended temperature.
	CAUTION
	<p>If the burner does not ignite the first time, turn the “POWER” toggle switch to the “OFF” position. Turn the toggle switch to “ON” again; the burner should ignite. If the burner still does not ignite, refer to 8.0.1 Symptoms: Burner will Not Ignite to determine the malfunction.</p> <p>Important: The solid material in the tank melts first around the walls, bottom, and around the center tower of the tank. The material temperature sensor is located by the wall, therefore, it is possible that at the beginning of the melting process the indicated temperature reaches operating value, but the material between the center tower and the outside wall of the tank is still solid. This is normal, and when the heated hose is ready for operation, most of the material in the tank will be melted and heated to the proper application temperature.</p>
7	Allow the heat transfer oil to continue to heat.

Chapter 5 Operating Instructions

Table 5-5.1 Starting the Burner for Standard Hose (continued)

Step	Action
8	<p>When the material reaches 275°F (135°C), the mixer light will illuminate which indicates the mixer can be engaged by turning the toggle switch at the control panel to “FORWARD” position. If the mixer does not move, allow the material to heat longer.</p> <p>Note: Mixer speed is preset at the factory and cannot be adjusted. The mixer cannot be engaged until the material reaches 275°F (135°C).</p>
	<p>CAUTION</p>
	<p>Jamming the mixer can cause the hydraulic oil to overheat and damage the machine.</p>
9	<p>The pump light will come “ON” when the material temperature reaches 275°F (135°C) indicating the temperature interlock will allow material pump operation.</p> <p>NOTE: Hose temperature display will not read an accurate pumping temperature until sealant is being pumped through the hose.</p> <p>Important: The oven must be at 300°F (162.8°C) for 20 minutes before attempting to pump. The oven temperature can be regulated by opening the slide gate to increase temperature or close slide gate to decrease temperature. Slide gate is located on passenger side.</p>
10	<p>When sealant reaches 325°F (162.8°C), open “TANK and RECIRCULATION valves, then close APPLICATOR VALVE”.</p>
11	<p>Reverse pump for 3-5 minutes by turning the pump toggle switch to “PUMP REVERSE” position. When pump turns freely, return switch to “ON STANDARD” position. This circulates hot material from bottom of tank back on top of cold material in the tank.</p>
12	<p>Increase heat transfer oil temperature to 500°F (260°C) and material temperature to manufacturers recommended application temperature (Approx. 380° (193.3°C)-400°F (204.4°C)).</p>
13	<p>When application of material is desired, remove hose from oven and connect to wand assembly (Hand tight only). Insert wand tip fully into shoebox with hand wand valve in “OPEN” position.</p>
14	<p>Open the “APPLICATOR VALVE”, close “RECIRCULATION VALVE”.</p>

Chapter 5 Operating Instructions

5.8 Loading Material into the Sealant Tank

This unit is equipped with a safety interlock system on the loading door. This system disables the mixer hydraulic system when the lid is open to stop the mixer from turning. This is a safety feature for the operator and should never be disabled for any reason.

CAUTION

Personal injury could occur if this safety system is disabled.

Table 5-6 Loading Material into the Sealant Tank

Step	Action
	WARNING
	Following this procedure prevents hot material from getting on operators and causing severe burns. Never throw blocks of material directly into tank. Hot material splash hazard will result.
1	To load material into the sealant tank first open the lid. For approximate material volume see Table 5-7 Material Tank Depth Chart
2	Place the solid material on the lid then close the lid.
3	Continue adding solid material at intervals to allow the mixer to rotate without jamming. Note: If blocks of solid material are added too quickly, jamming results and slows down the melting process. Note: When sealant placement volume is low, or the crew has stopped working for lunch, hot oil and material temperatures can equalize. To lower material temperature add a few blocks of cold sealant. This may not be an option if the tank is full.

Chapter 5 Operating Instructions

5.8.1 Material Tank Depth Chart

Table 5-7 Material Tank Depth Chart

DEPTH OF MATERIAL TANK	CAPACITY IN GALLONS BOTTOM UP	CAPACITY IN LITERS BOTTOM UP	CAPACITY IN GALLONS TOP DOWN	CAPACITY IN LITERS TOP DOWN
1	13.51	51.14	381.26	1443.23
2	27.16	102.81	367.23	1390.12
3	40.93	154.94	353.2	1337.01
4	54.70	207.06	339.17	1283.90
5	68.47	259.19	325.14	1230.79
6	82.24	311.31	311.11	1177.68
7	96.01	363.44	297.08	1124.57
8	109.78	415.56	283.05	1071.46
9	123.55	467.69	269.02	1018.35
10	137.32	519.81	255.25	966.23
11	151.09	571.94	241.48	914.10
12	164.86	624.06	227.71	861.98
13	178.63	676.19	213.94	809.85
14	192.40	728.31	200.17	757.73
15	206.17	780.44	186.4	705.60
16	219.94	832.56	172.63	653.48
17	233.71	884.69	158.86	601.35
18	247.48	936.81	145.09	549.23
19	261.28	989.05	131.32	497.10
20	275.25	1041.93	117.55	444.98
21	289.27	1095.01	103.78	392.85
22	303.29	1148.08	90.01	340.72
23	317.31	1201.15	76.24	288.60
24	331.34	1254.26	62.47	236.47
25	345.37	1307.37	48.7	184.35
26	359.40	1360.48	34.93	132.22
27	373.43	1413.59	21.16	80.10
28	387.46	1466.70	7.39	27.97
28.56	395.29	1496.34	0	0.00

Chapter 5 Operating Instructions

5.9 Dispensing the Material

Table 5-8 Dispensing the Material – Electric Hose

Step	Action
WARNING	
	<p>Put on protective clothing, gloves, hard-soled shoes, and face shield or safety glasses when operating or filling this machine. Read the entire manual before operating the machine.</p> <p>Never point the wand at any part of the body or at any other person. Hot material can cause severe burns.</p> <p>Important: Some difficulty may be encountered when starting up on cold days. Although the wand is designed to heat the material all the way down to the tip, on cold days you can place the tip of the wand into the shoebox to facilitate material melting in the valve. Insert the wand tip for only a short time before proceeding.</p>
1	When the material and hose have reached manufacturer’s application temperature, you are ready to dispense material.
2	Turn the pump speed control to the lowest setting by turning the speed control knob fully clockwise.
3	Insert the wand tip into the shoebox, depress trigger on the wand and slowly increase pump speed until the pump motor starts to turn.
4	<p>Adjust the pump speed for the desired flow rate for the application. The rate of flow may be varied while the pump is running.</p> <p style="text-align: center;">CAUTION</p> <p>Never open flow control more than 2 full turns when using an electric hose as this will cause premature material pump wear.</p> <p>Important: It may be necessary to use the recirculation with the electric hose anytime the machine is not going to be used for more than 5-10 minutes when the ambient temperature is below 40°F or not being used for 20-30 minutes in warmer weather. This is critical after material is up to operating temperature and burner is running intermittently, the oven will cool and all material in the plumbing and pump will solidify. To get the oven hot enough to start pumping again, add several blocks of sealant to lower the material temperature enough to cause burner to ignite. This may not be an option if the tank is already full.</p>

Chapter 5 Operating Instructions

Table 5-9 Dispensing the Material – Standard Hose

Step	Action
WARNING	
	<p>Put on protective clothing, gloves, hard-soled shoes, and face shield or safety glasses when operating or filling this machine. Read the entire manual before operating the machine.</p> <p>Never point the wand at any part of the body or at any other person. Hot material can cause severe burns.</p>
1	When the material has reached manufacturer’s application temperature, you are ready to dispense material.
2	Turn the pump speed control to the lowest setting by turning the speed control knob fully clockwise.
3	Insert the wand tip into the shoebox, open the ball valve on the wand and adjust the control valve to get close to the desired material flow for the application.
4	Open recirculation valve to get the desired flow rate.
5	This method of operation will give maximum pump life. If the sealant does not flow from the applicator wand, close hand wand valve and place hose and wand back into the oven to allow the sealant to become more liquid, and then repeat procedure.
6	Once sealant is flowing freely, reverse pump and install desired sealing tip or disk and you are ready to begin sealing. See Section 10.0 Tools and Accessories for other sealing tips and disk.
CAUTION	
Extreme care should be taken when changing or installing sealing tips. Always engage pump reverse if sealant is hot. Hot sealant can cause severe skin burns.	

5.10 Shutting Down and Cleaning Out the Machine

When shutting down the machine for the day, CrafcO recommends leaving the melter about half full with material. This will give a fairly rapid heat up rate in the morning, but allows enough material to start dispensing right away when the material becomes molten.

Chapter 5 Operating Instructions

Table 5-10 Shutting Down with an Electric Hose

Step	Action
1	Leaving the hose in the boom, swing the boom counterclockwise towards the front of the machine and lock the boom into position with the latch provided.
	CAUTION
	DO NOT kink or twist the hose or permanent damage may result.
2	Place the wand in the wand holder and lock the wand into position with the latch provided.
3	Reverse the pump while removing tip adapter and or duckbill. Continue to reverse for approximately 30 more seconds.
4	Close the "APPLICATOR VALVE" and "TANK VALVE".
5	Turn the mixer toggle switch to the "OFF" position.
6	Turn the "POWER" switch to the "OFF" position.
7	Stop the engine by turning the key to the "OFF" position.

Table 5-11 Shutting Down with a Standard Hose

Step	Action
1	Close recirculation valve and reverse the pump for approximately 3 minutes.
1a	Remove wand from hose and wrap hose up in oven while reversing the pump.
2	Close the "APPLICATOR VALVE".
3	Open recirculation valve. Close the "TANK VALVE".
4	Turn "Off" pump reverse switch.
5	Turn the mixer toggle switch to the "OFF" position.
6	Turn the burner toggle switch to the "OFF" position.
7	Stop the engine by pressing the "OFF" button on the engine controller. The engine will go into an "IDLE COOL" for ten seconds and then the engine will shut down and stop.
8	Turn the "MAIN POWER" switch to the "OFF" position..
	IMPORTANT: Ensure the hose is not touching the tank wall or plumbing.

Chapter 5 Operating Instructions

5.11 Overnight Heater Use

An overnight heater rod is available as an option. PN 24190 for 110V, and PN 24194 for 220V. The overnight heater may be used to maintain an overnight heat transfer oil temperature of approximately 200-250°F (93.3°C)

Table 5-12 Overnight Heater Use

Step	Action
	WARNING
	The overnight heaters are for overnight use only. If the overnight heater is used, the material must be dispensed the next day. If the material can't be dispensed, the machine needs to be heated to mixing temperatures, and agitated to prevent settling. If you don't dispense the material after 1 nights use, you risk damaging the material and possibly the machine due to settled material, which can harden in the bottom of the material tank
1	Attach each heater power cord to its own suitable extension cord.
2	Attach each extension cord to its own outlet rated for 15 amps minimum.
	CAUTION
	Certain machines may have 2 overnight heaters depending on the size of the material tank. Attaching both heaters to the same outlet will most likely pop the circuit breaker inline from the power source. Combining both heaters together will draw too much amperage for most common 15 amp circuits.
	WARNING
	<p>Suitable extension cord size requirements for 110 Volt use: 25-50 FT • 16-20 Amps • 12 Gauge (Heavy Duty) or 10 Gauge (Extra Heavy Duty) 100 FT • 16-20 Amps • 10 Gauge (Extra Heavy Duty)</p> <p>Suitable extension cord size requirements for 220 Volt use: 25-50 FT • 8-10 Amps • 14 Gauge (Medium Duty) or 12 Gauge (Heavy Duty) 100 FT • 8-10 Amps • 12 Gauge (Heavy Duty)</p> <p>Failure to use the correct size extension cord could result in damage and possible fire!</p>
3	Disconnect the heaters when using the machine's burner system.
	CAUTION
	Do not use the heaters without heat transfer oil in the tank. Doing so will overheat and damage the heater, and it will have to be replaced.

Chapter 5 Operating Instructions

5.12 Storing the Machine

Store the machine in an area where moisture cannot enter the heating system such as heat transfer oil tank, etc. Extended down time can cause moisture build up in the heating tank.

Evidence that moisture has collected in the heat transfer oil is a constant popping noise. If this popping noise is heard, warm the heat transfer oil to 300°F for two to three hours to evaporate the moisture. Failure to follow this procedure will cause the heat transfer oil to overflow the tank resulting in possible machine damage and/or personal injury.

Best practice is to check in the material tank prior to starting the burner. If water is present, try and remove as much as possible, heat the material to 300°F for two to three hours to evaporate the moisture. Failure to follow this procedure will cause the material to overflow the tank resulting in possible machine damage and/or personal injury.

Store the machine for longer periods with the material tank empty.

Chapter 6 Maintenance Instructions

6.0 Maintenance Instructions

This chapter contains all normal maintenance instructions to properly maintain your machine.

6.1 Engine

Refer to the manufacturer's operating and maintenance instructions for the engine.

6.2 Hydraulic System

Check hydraulic fluid daily.

Change hydraulic filter every 250 hours of machine operation. Replace if necessary.

Change hydraulic fluid every 500 hours of operation.

6.3 Heat Transfer Oil

Check the oil level at the start of every day. See [Table 5-1 Preparing the Machine for Start Up](#), Step 4.

Change the oil every 500 hours of machine operation or 1 year, whichever comes first. Failure to follow this oil change interval will result in machine damage. See [6.18 Changing the Heat Transfer Oil](#) for procedure.

6.4 Wheel Bearing

Pack the wheel bearing every 24,000 miles or every two years, whichever comes first. Use a good grade of bearing grease.

6.5 Material Sensor Tube

Check for heat transfer oil in tube every 50 hours of operation. 2 ounces required.

6.6 Pump Packing Adjustment and Replacement

Material pump packing should leak a small amount (5-10 drops per minute) during normal use. If packing adjustment is required, operate the pump under normal conditions before making any adjustments. Tighten packing gland nuts evenly (1-2 flats on the nut) until there is 5-10 drops per minute. **DO NOT OVER TIGHTEN** packing gland as that will shorten the life of the packing and wear out the sealing surfaces faster.

To replace packing, remove two nuts, packing gland clip, and packing gland halves. Use a packing hook to remove all seven of the packing rings. New packing rings should be installed one ring at a time, with the joints staggered 180° apart. Each ring should be seated firmly before the next ring is installed.

The packing gland nuts should first be evenly tightened with a wrench to seat the packing firmly in the stuffing box and against the shaft. **DO NOT** over tighten the packing. The gland nuts should then be backed off until finger tight. Follow adjusting pump packing at the beginning of this section.

6.7 Lug Nuts

Torque all nuts/bolts before first road use and after each wheel removal. Check and torque after the first 10 miles, 25 miles, and again at 50 miles. Check periodically thereafter.

Torque in stages as follows:

Chapter 6 Maintenance Instructions

First stage 20-25 foot-pound (ft-lb)

Second stage 50-60 foot pound (ft-lb)

Third stage 90-120 foot pound (ft-lb)

Tighten bolts and nuts in the sequence shown in [Fig. 6-1](#).

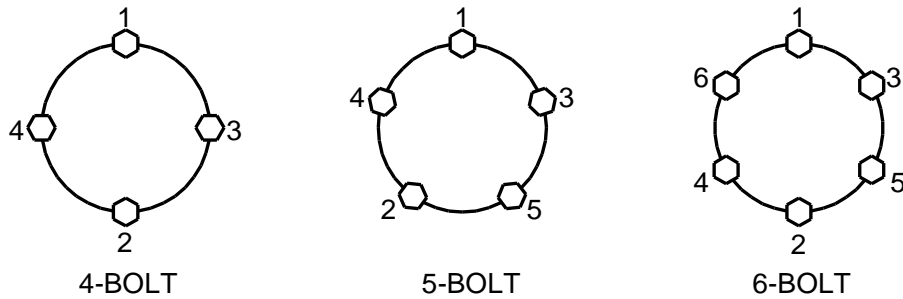

Fig. 6-1 Lug bolt Tightening Sequence

6.8 Brakes

Check the brakes daily.

6.9 Tongue Jack

Lubricate the tongue jack, using a good grade of bearing grease.

Chapter 6 Maintenance Instructions

6.10 Temperature Control Calibration

Check the control knob calibration weekly. Calibrate by turning the knob counterclockwise. If the marks do not align, loosen screw in knob and align the line on the control knob with the calibration mark on the scale plate. (See Fig. 6-2)

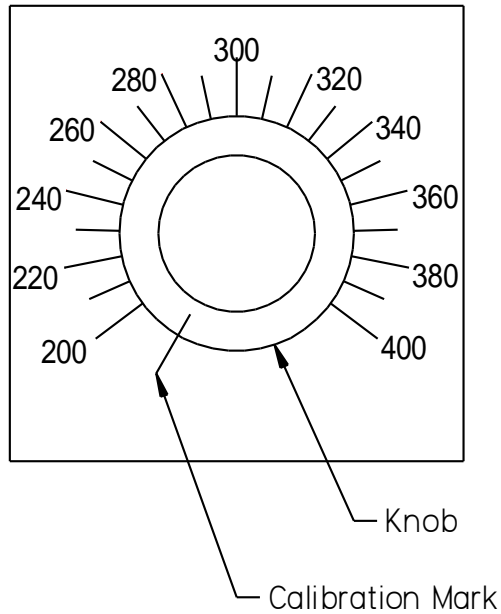

Fig. 6-2 Temperature Control Calibration

Chapter 6 Maintenance Instructions

6.11 Maintenance Chart

Table 6-1 Maintenance Chart

Possible Cause	Procedure	Hours			
		8	50	250	500
Engine check oil level	Refer to the manufacturer's instructions for the engine	X			
Other engine maintenance	Refer to the manufacture's operating and maintenance instructions for the engine				
Material Sensor Tube	Check for HTO fluid		X		
	Add	As needed			
Heat Transfer Oil	Check	X			
	Change				X
Hydraulic Oil	Check	X			
	Change				X
Hydraulic Oil Filter	Change			X	
Burner	Check burner box insulation				X
	Clean CAD cell				X
	Check Electrodes				X
	Check Flame Retainer/Head				X
	Replace burner nozzle				X
	Replace Fuel Filter				X
Wheel Bearings	Clean and re-pack using a good grade of bearing grease	Every 24,000 miles or two years			
Tongue Jack	Grease using a good grade of bearing grease	Once a year			
Material Tank	Scrape out built up material in the material tank	Once a year or as needed			
Material Sensor Guard	Scrape out built up material around guard				X

For a list of parts required for maintenance see [Table 6-3 General Maintenance Parts](#).

Chapter 6 Maintenance Instructions

6.12 Service Instructions

Table 6-2 Service Instructions

Step	Action
1	Do a general inspection of the machine at least once a week.
2	Replace all worn or damaged parts. Note: Keep regular replacement items in stock for emergency repairs to prevent costly downtime. See Table 6-4 Recommended Spare Parts
3	Make necessary adjustments and tighten all loose nuts or screws.
4	Watch for leaks. Tighten fittings or repair as necessary.
5	Clean the external surfaces of the machine at regular intervals. Note: Refer to the material manufacturer's instructions for recommendations.
6	Follow the recommended maintenance per Table 6-1 Maintenance Chart

For service, find a list of authorized Distributors and service centers at Crafco.com/Distributors.

6.13 General Maintenance Parts

Table 6-3 General Maintenance Parts

Quantity	Description	Machine	Part No.
1	Fuel Filter	All	41867
1	Oil Filter	46400SB 46400EB	45389
1	Air Filter	46400EB 46400SB	45391
1	Nozzle, Burner	All	42559
1	Packing, Material Pump	All	29990S
1	Hydraulic Oil Filter	All	45438
Table 6-5	Hydraulic Oil	All	Table 6-5
Table 6-5	Heat Transfer Oil	All	Table 6-6

Chapter 6 Maintenance Instructions

6.14 Recommended Spare Parts

Table 6-4 Recommended Spare Parts

Quantity	Description	Machine	Part No.
1	Temperature Controller, Material	All	51672
1	Temperature Controller, Electric Hose	46400EB	51691
1	Temperature Controller, Hot Oil	All	43391
1	Temperature Controller, Material	46400SB	43397
1	DC Controller	All	42335
1	Coupling, Fuel Pump	All	41970
1	Electric Hose, 15'	46400EB	52400
1	Sealant Hose, 20'	46400SB	27009

6.15 Recommended Fluids and Lubricants

Table 6-5 Recommended Fluids and Lubricants

Application	Recommended	Full Point	Machine No.
Fuel	#1 Cold Climate #2 Warm Climate	30 Gals.	All Models
Engine Oil	Refer to engine manual	3 Qt.	PN 46400EB, 46400SB
Hydraulic Oil	Shell AW Hydraulic 46	24 Gals.	All Models
Heat Transfer Oil	Shell Turbo T 68 (Group II)	48 Gals.	All Models
Legend: PN 46400EB EZ1500 Electric Base PN 4640SB EZ1500 Standard Base			

Chapter 6 Maintenance Instructions

6.16 Applicable Brands of Heat Transfer Oil

Table 6-6 Applicable Brand of Heat Transfer Oil

Manufacturer	Product Name	Crafco Heat Transfer Fluid
Chevron	Heat Transfer Oil Grade 46	Shell Turbo T 68 (Group II)
Citgo	Hytherm Oil 46	Shell Turbo T 68 (Group II)
Conoco	Hydroclear Heat Transfer Oil	Shell Turbo T 68 (Group II)
Fina	Vulcan Heat Transfer Oil 46	Shell Turbo T 68 (Group II)
Lubrication Engineers	Heat Transfer Oil	Shell Turbo T 68 (Group II)
Exxon Mobile	Caloria HT 43	Shell Turbo T 68 (Group II)
Mobil	Mobiltherm 43	Shell Turbo T 68 (Group II)
Mobil	Mobiltherm 603	Shell Turbo T 68 (Group II)
Phillips 66	Heat Transfer Oil #3	Shell Turbo T 68 (Group II)
Phillips 66	Magnus Oil 68	Shell Turbo T 68 (Group II)

CAUTION

The heat transfer oil in this machine is a grade that has been tested and recommended by Crafco, Inc. Using a grade of oil not specifically recommended by Crafco, Inc., is cause for warranties to be voided.

All oils subjected to high temperatures deteriorate with time and lose many of their characteristics. Tests conducted by Crafco, Inc. have determined that for best results and safety, the heat transfer oil in this machine must be drained and replaced with Crafco, Inc. recommended oil after five hundred (500) hours of machine operation or one (1) year, whichever occurs first.



6.17 Typical Heat Transfer Oil Specifications

ISO	68
Flash Point, COC	445°F
Viscosity @ 100°F-SUS	325
Viscosity @ 210°F-SUS	50
Viscosity Index	95-100
Pour Point	0°F
Carbon residue	1%

Chapter 6 Maintenance Instructions

6.18 Changing the Heat Transfer Oil

Table 6-7 Changing the Heat Transfer Oil

Step	Action
1	To facilitate easier draining of the heat transfer oil, heat the oil to approximately 100°F (38°C).
	WARNING
	Wear proper PPE (safety glasses, face shield, gloves, long sleeve shirt) to prevent bodily injury while servicing the heat transfer oil. Use suitable metal drain pans and containers that can withstand the high temperatures of the heat transfer oil.
2	Locate the heat transfer oil drain plug on the underside of the melter directly below the material tank. See Fig. 6-3 Heat Transfer Oil Drain and Fill Ports .
3	Remove the pipe cap from the drainpipe with a pipe wrench and allow the oil to drain into an appropriately sized container. Note: It may be necessary to use a second wrench to keep the drainpipe from turning.
4	Remove the plug and open the breather ball valve located on the rear driver's side of the material tank. See Fig. 6-3 Heat Transfer Oil Drain and Fill Ports . Place a suitable drain pan with at least 10 oz (137cc) capacity below the ball valve to collect any oil left in the breather tube. This will ensure the oil in the center heating tower is drained during the process.
5	If oil fails to drain from the tank, this may be an indication that the oil has crystalized (coked up) inside of the drainpipe. Use a long screwdriver or steel rod to break up the hardened material from the drainpipe to allow the oil to flow. Note: Raise the front of the machine slightly to allow oil to flow towards the drainpipe.
6	As an alternative draining method, a 1/4" schedule 40 pipe attached to an oil pump, can be inserted through the HTO fill port or through the expansion tank where the dipstick is located. The end of the pipe should be cut at a slight angle to prevent blocking of the pipe, so the oil can be pumped out. Make sure the pipe is long enough to go to the bottom of the tank.
7	After the oil has completely drained, replace the pipe cap onto the drainpipe and tighten. Close the breather valve, but do not install plug yet.
	Filling Steps
8	Fill the tank using the fill port next to the overflow reservoir to the correct level on the dipstick with a recommended oil that meets ISO 68 specification. See section 6.16 and 6.17 . Also see, Table 5-1 Step 4 for checking HTO level.
	WARNING
	Wear proper PPE (safety glasses, face shield, gloves, long sleeve shirt) to prevent bodily injury while servicing the hot heat transfer oil.
9	To fill the center heating tower, since it is taller than the fill point on the dipstick, (see Fig. 6-4 Center Heating Tower Diagram) the machine will need to be heated to expand the oil volume. Turn on the burner. As the oil heats, place a suitable metal drain pan below the breather valve. When the oil gets to 400° F (204°C) turn of the burner.
10	Open the breather ball valve until you see a few ounces of oil flow continuously, then close the ball valve and install the plug.
11	The machine is now ready to be used. It will be a little low on oil, so once the machine cools back to ambient temperatures around 70° F (21° C) you will need to check the oil level on the dipstick and top off as needed to replenish the oil that went into the center heating tower during the filling process.

Chapter 6 Maintenance Instructions

CAUTION

Do not overfill the heat transfer oil tank as the oil expands when heated and may overflow.

Fig. 6-3 Heat Transfer Oil Drain and Fill Ports

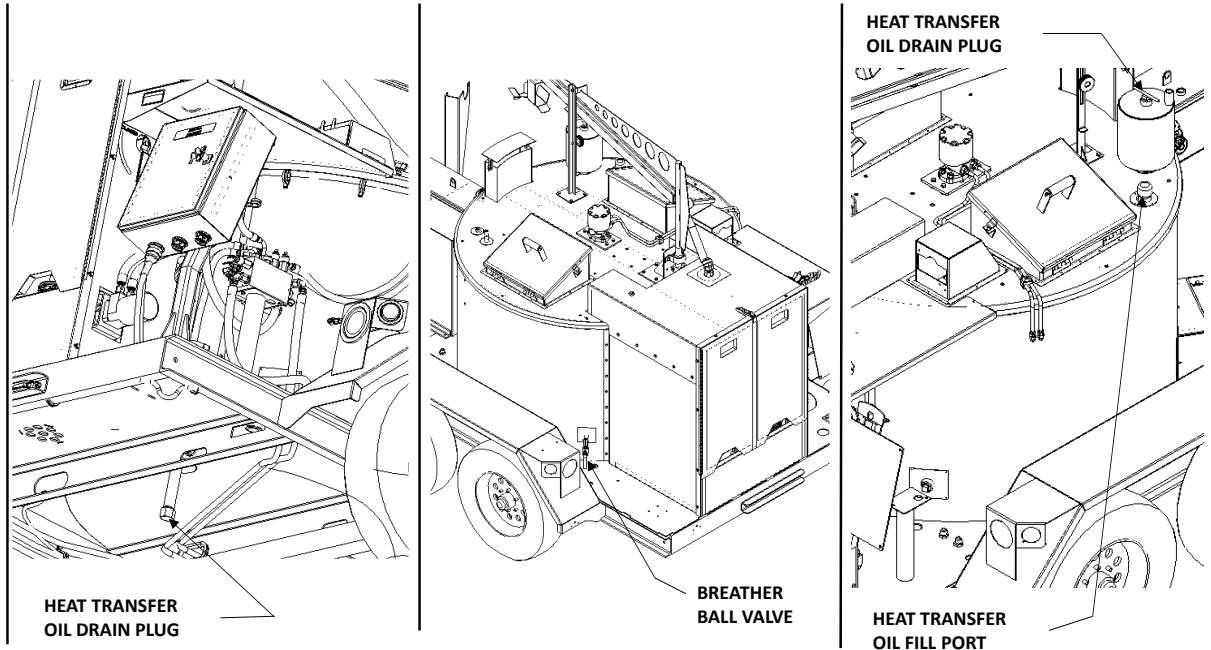
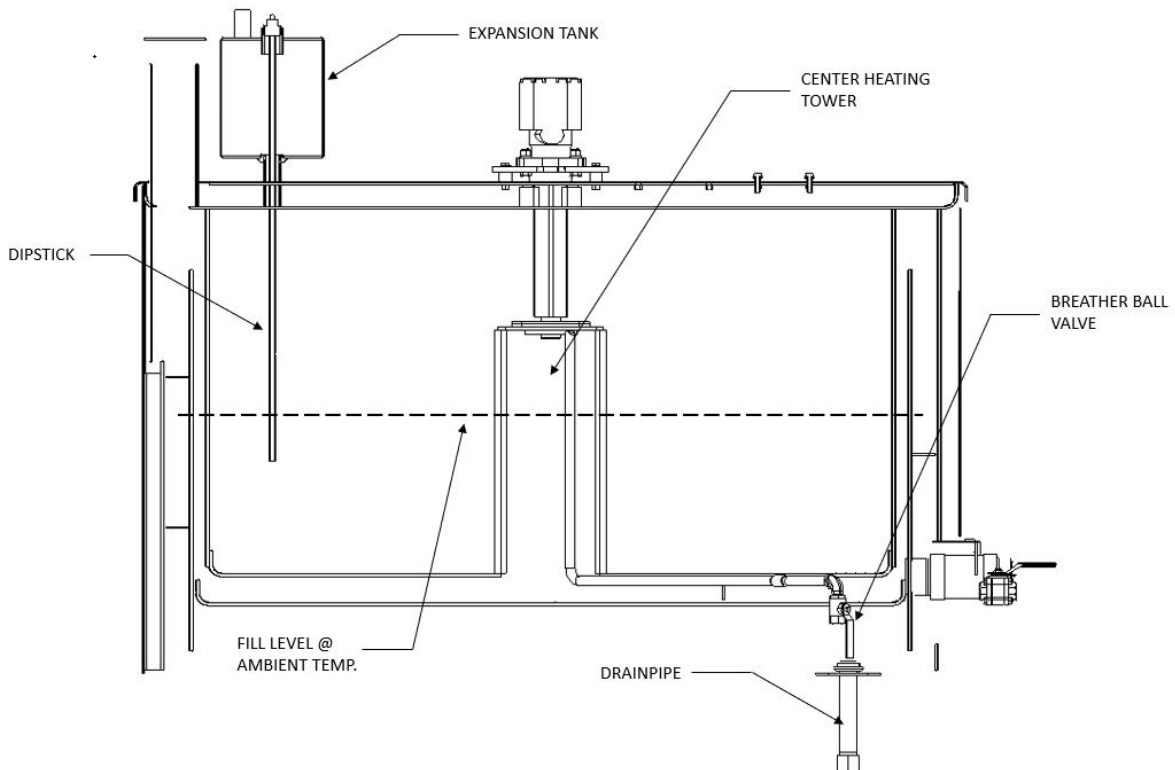

Fig. 6-4 Center Heating Tower Diagram



Chapter 6 Maintenance Instructions

6.19 Cleaning Material Tank and Sensor Area

The material tank needs to be cleaned every year or as needed for proper operation. As the machine is used, material builds up around the tank walls and sensor guard. The built up material prevents heat from getting to the fresh material and causes longer heat up times. The built up material will also prevent the material temperature sensor from reading as accurately because it becomes insulated from the fresh material. The coked material needs to be scraped or chipped from the tank walls. The area between the sensor and sensor guard needs to be cleaned also for proper temperature sensing. An air chisel with various sized blades usually works best to break up the material and remove it from the walls. Once the walls and sensor guard areas are cleaned, remove all the loose chunks from the tank, and vacuum out any smaller pieces.

6.20 Cleaning the Melter

We recommend using Orange-Sol industrial cleaner for cleaning the exterior of the machine. The cleaner can be found at the following website; <https://www.orange-sol.com/industrial-formula/>.

Chapter 6 Maintenance Instructions

6.21 Material Pump Replacement

Table 6-8 Material Pump Replacement

Step	Action
1	Close "TANK VALVE".
2	Remove the front of the heat compartment. This is not necessary but will make the job easier.
	WARNING
	The material in the sealant tank is extremely hot. Bodily contact with hot sealant can cause severe burns.
3	Remove the side access panel.
4	Remove the 6 bolts from both flanges of the double elbow and remove double elbow.
5	Remove the 8 bolts from the material suction pipe flange.
6	Remove the 4 bolts from the hydraulic motor and loosen setscrew in pump/motor coupling. Remove motor from pump motor mount.
7	Remove the 4 bolts from the pump base and remove pump from pump base.
8	Remove the material suction pipe and the flanged nipple assembly from the material pump. Note orientation of bolt holes in flanges.
9	Install material suction pipe and flanged nipple assembly into new pump.
10	Install material pump onto pump base. Flange gasket P/N 41043 will also need to be installed at this time using (6) 3/8-16 x 1" bolts, (2) flat washers per bolt (1 on each side of flange), lock washer, and upset hex nuts. Use (4) 1/2-13 x 1 3/4" bolts, flat washer, lock washer, and hex nuts to attach pump to pump base. Leave all hardware loose until everything is installed.
11	Install double elbow using new flange gaskets P/N29050, 3/8-16 x 1" bolts, (2) flat washers per bolt (1 on each side of flange), lock washer, and upset hex nut. Leave all hardware loose until everything is installed.
12	Install hydraulic motor on material pump using (4) 3/8-16 x 1 1/4" bolts and lock washers. Tighten setscrew on pump/motor coupling.
13	Tighten all bolts and nuts.
14	Replace heat compartment using (11) 1/4-20 x 3/4" bolts, flat washers, and lock washers.
15	Replace access panel using (3) #10 x 3/8 Self Tapping Screw.

Chapter 6 Maintenance Instructions

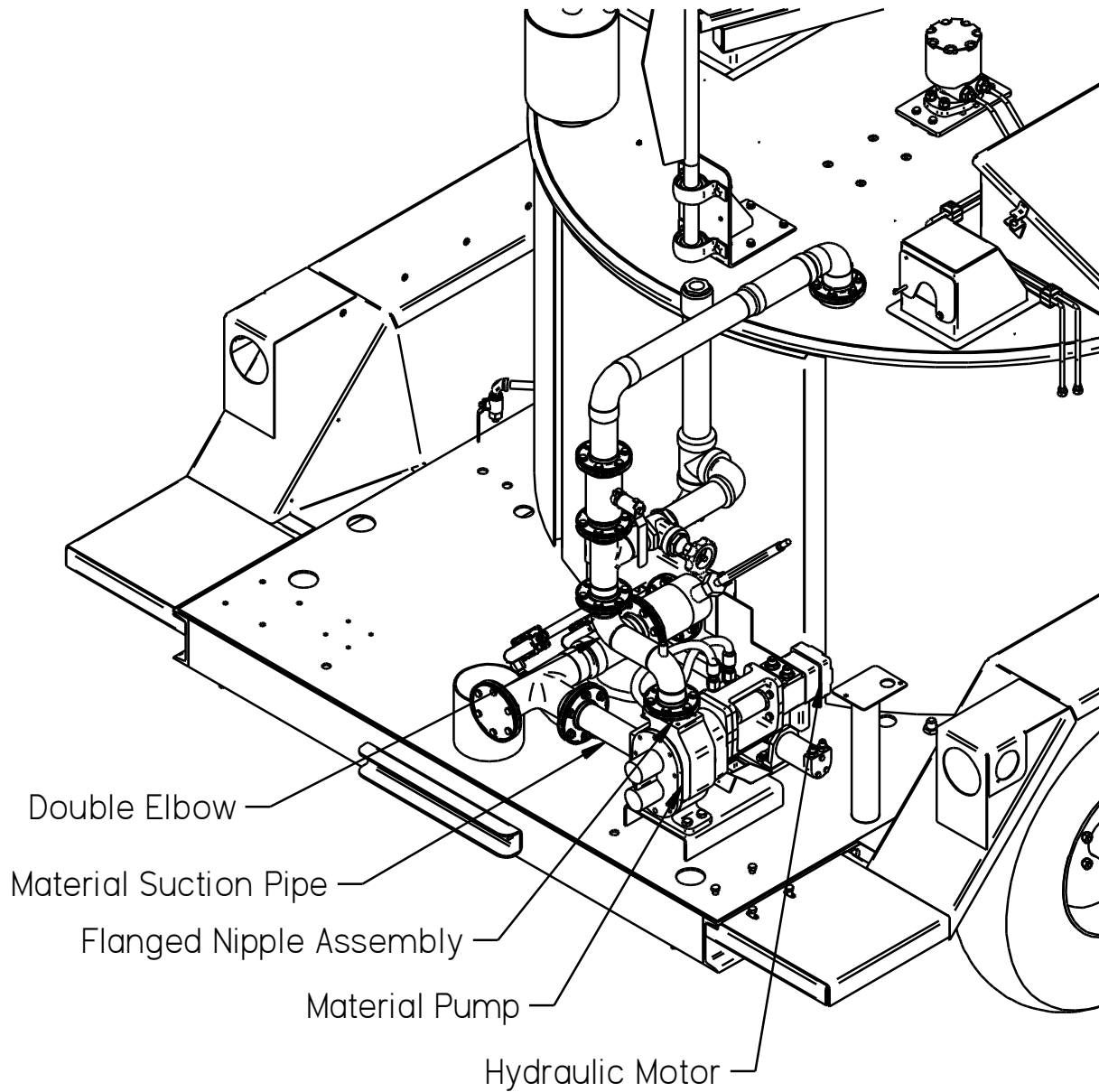

Fig. 6-5 Material Pump Replacement

Chapter 6 Maintenance Instructions

6.22 Wand Repair Instructions

The following sections will address how to replace the wand handle, wand cable, switch, and terminal block of the 52200 wand assembly. Actuator, actuator lock, and spring can also be replaced. See [9.15 Wand Assembly](#) for parts breakdown.

6.22.1 Cable Replacement

1. Disconnect the cable from the electric hose. Lay wand on flat surface with socket head screws facing up.
2. Remove (7) #10-32 x 1" socket head screws and (2) 1/4-20 x 1/2" socket head screws.
3. Carefully remove top handle half. **Caution:** Actuator pin may lift actuator and spring from bottom handle half. Do not lose spring or pin.
4. Remove red and orange wire from switch.
5. Remove green, white, and black wires from terminal block.
6. Remove cable from handle.
7. Replace cable in handle. Note: Look for flats on strain relief of cable that correspond to flats on handle.
8. Install red wire on top of switch (see [Fig. 6-1 Switch Wire Location](#)), then install orange wire on (NO) terminal (top rear of switch).
9. Strip green, white, and black wires 3/8" and twist wires strands then install (**Note** white black wire is routed under switch see [Fig.6-2 Wire Routing](#)) on open terminals of terminal block. Make sure to install completely under the clamp before tightening screws. Torque screws to 16 in-lbs. Bend all (3) wires over the top of terminal block (see [Fig.6-3 Terminal Block Wiring](#)).
10. Replace top wand handle half.
11. Use blue Loctite® on all external handle screws before installation. Install (7) #10-32 x 1" socket head screws hand tight, then install (2) 1/4-20 x 1/2" socket head screws hand tight. Now torque all #10-32 screws to 12 in-lbs. and all 1/4-20 screws to 25 in-lbs.
12. Reconnect cable to electric hose.

6.22.2 Switch Replacement

1. Follow steps 1-4 from [6.22.1](#) above.
2. Remove (2) #4-40 x 1/2" pan head screws from switch, then remove switch from handle.
3. See [Fig.6-4 Actuator Spring Location](#) and [Fig.6-5 Actuator / Trigger Assembly](#) for proper assembly of actuator to switch.
4. Replace switch and install (2) #4-40 x 1/2" screws and tighten.
5. Follow Steps 10-12 from [6.22.1](#) above.

6.22.3 Terminal Block Replacement

1. Follow steps 1-4 from [6.22.1](#) above.
2. Remove (2) #10-32 x 5/8" round head machine screw from terminal block then remove terminal block from handle.
3. Replace terminal block and install (2) #10-32 x 5/8" screws and tighten.
4. Follow steps 10-12 from [6.22.1](#) above. If actuator, pin, and spring need to be reinstalled, see [Fig.6-4 Actuator Spring Location](#) and [Fig.6-5 Actuator / Trigger Assembly](#).

Chapter 6 Maintenance Instructions

6.22.4 Wand Handle Replacement

1. Follow steps 1-6 from 6.22.1 above.
2. Remove actuator, actuator lock, pin, and spring.
3. Remove (2) #4-40 x 1/2" pan head screws from switch, then remove switch from handle.
4. Remove (2) #10-32 x 5/8" round head machine screw from terminal block then remove terminal block from handle.
5. Flip wand over and remove the remaining (2) 1/4-20 x 1/2" screws from the handle. Remove handle from wand tube.
6. Install new handle by reversing previous steps.



Fig. 6-1 Switch Wire Location



Fig.6-2 Wire Routing

Chapter 6 Maintenance Instructions



Fig.6-3 Terminal Block Wiring

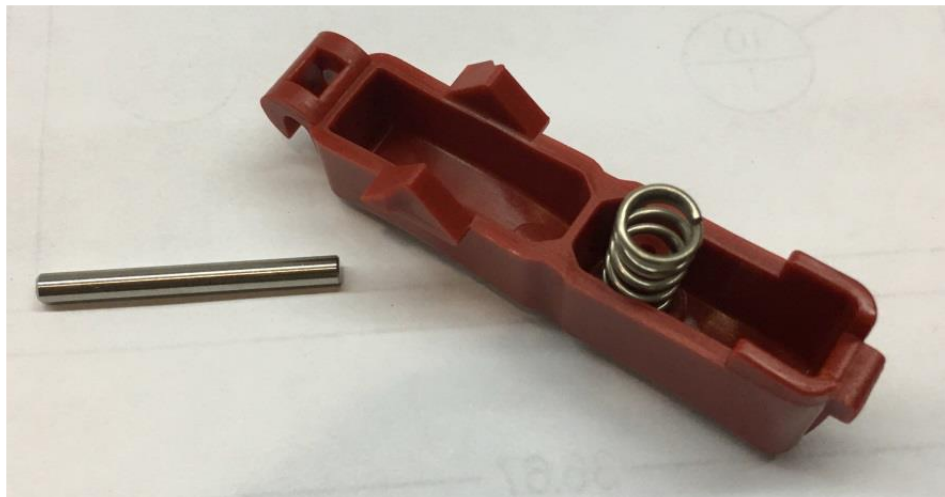

Fig.6-4 Actuator Spring Location

Chapter 6 Maintenance Instructions

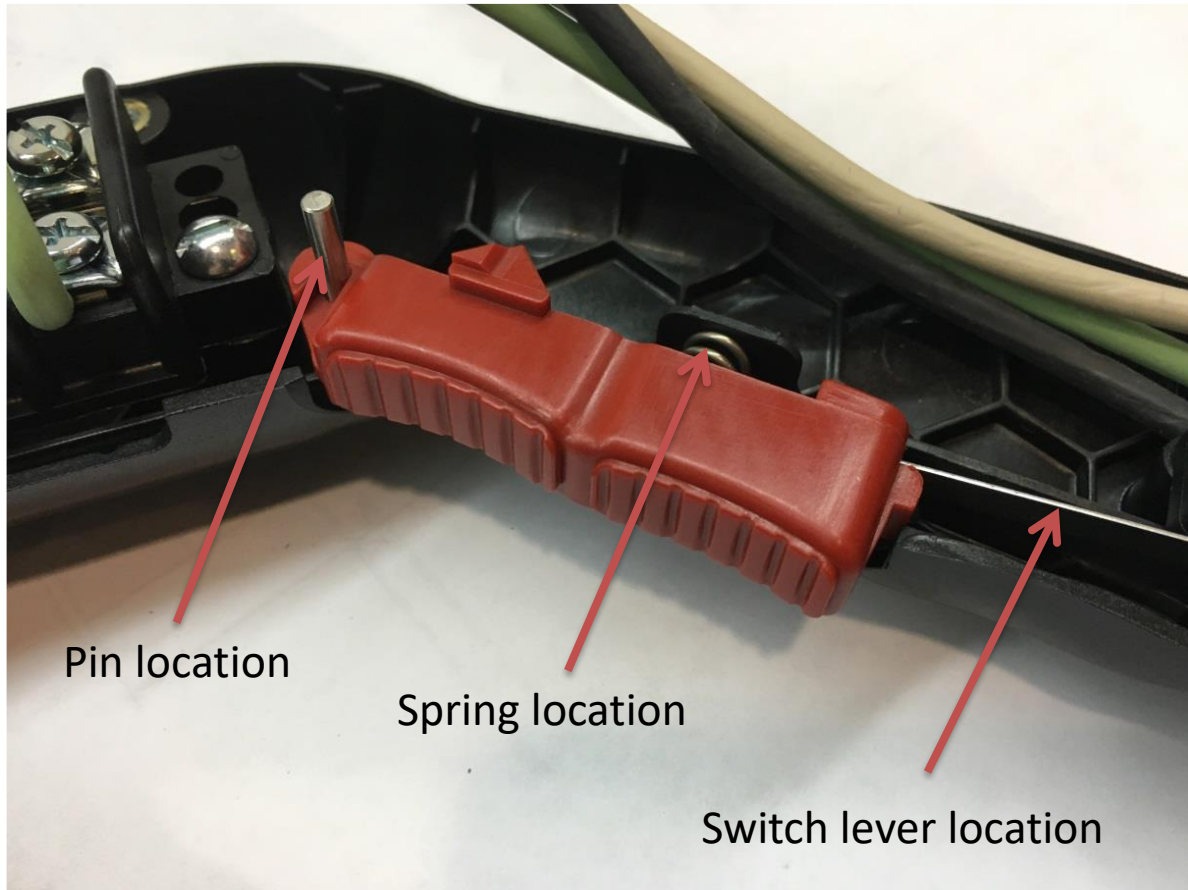

Fig.6-5 Actuator / Trigger Assembly

Chapter 6 Maintenance Instructions

6.23 Burner Fuel Filter Replacement

For machines that have a separate fuel filter for the burner, follow the steps below to replace the fuel filter.

Table 6-9 Burner Fuel Filter Replacement

Step	Action
1	The machine should be off and cooled to ambient temperature.
2	Place a drain pan below the burner fuel filter assembly.
3	Close the ball valve that is located inline before the burner fuel filter assembly.
4	Unscrew the filter from the assembly using an oil filter or strap style wrench.
5	Screw the new filter into place and tighten by hand.
6	Open the ball valve to allow fuel to flow.
7	Turn on the power key and turn on the main power switch. The burner should self-prime and start. It may take a couple cycles to fill the new fuel filter and bleed the fuel system.
8	Once the burner is running, check for any fuel leaks and tighten the filter if needed.
9	Turn off the main power switch and power key.

Chapter 7 How to Use a Multimeter

7.0 How to Use a Multimeter

Melters use 12-volt direct current (DC) to power the burner, hydraulic valves, and trigger on electric wand. The DC power is from a 12-volt battery.

The electric hose and wand uses 24-volt 3-phase alternating current (AC). The AC power is from the generator which hangs under the radiator. This system has no reference to ground so there is no possibility of electrical shock unless you are between 2 of the phases. **NOTE: ONLY CHECK AMPERAGE ON A HOSE WITH A CLAMP-ON AMP METER.**

12-volt DC power has little danger of electrical shock. Care must still be taken when dealing with DC power systems because it is capable of producing large amounts of current.

7.1 Checking DC Voltage with a Multimeter

Connect the probes to the meter.

Set the range to a position that includes 12-volts or higher.

Touch the red probe to the positive side of accessory and black probe to ground. If the item you are checking has a ground wire attached then use that ground or you can use a non-painted surface on the frame.

7.2 Checking AC Voltage with Multimeter

Connect the probes to the meter (See [Fig. 7-1 Standard Multimeter](#)).

Set range to a position that includes 24-volts or higher.

There are three steps to test the generator voltage. All 3 values should be in the range of 24-30 volts AC.

- Touch red probe to the white wire of the generator and the black probe to the green wire of the generator.
- Next move black probe to black wire.
- Then move red probe to green wire.

7.3 Checking Resistance (Ohms)

Connect probes to the meter (See [Fig. 7-1 Standard Multimeter](#)).

Note: When checking Ohms the circuit cannot be completed. This means one end of the wire will need to be disconnected.

7.3.1 How to Check Wire Continuity

Set the meter to “Audible Continuity”.

Now touch the probe to each end of the wire in question. The meter will read “0” on the screen and make an audible beep if the wire has continuity from end to end.

7.3.2 How to Check RTD Sensor

Set dial to Ohms Ω . If your meter has different ranges set to 2K or 2000 ohm range.

Touch one probe to each screw or wire of the sensor. The meter will read X.XX if in the 2K range or XXX.X if in the 2000 range.

Chapter 7 How to Use a Multimeter

7.4 Checking Amperage

The Multimeter can be used to check amperages under 10 amps in AC or DC current. When checking the amperage of the electric hose **always use a clamp-on amp meter (See Fig. 7-2 Clamp-On Amp Meter/Multimeter)**. The amperage in the hose can reach as high as 35 amps. Clamp the meter around one wire at a time. Remember most clamp-on meters do not work on DC current.



Fig. 7-1 Standard Multimeter

Chapter 7 How to Use a Multimeter

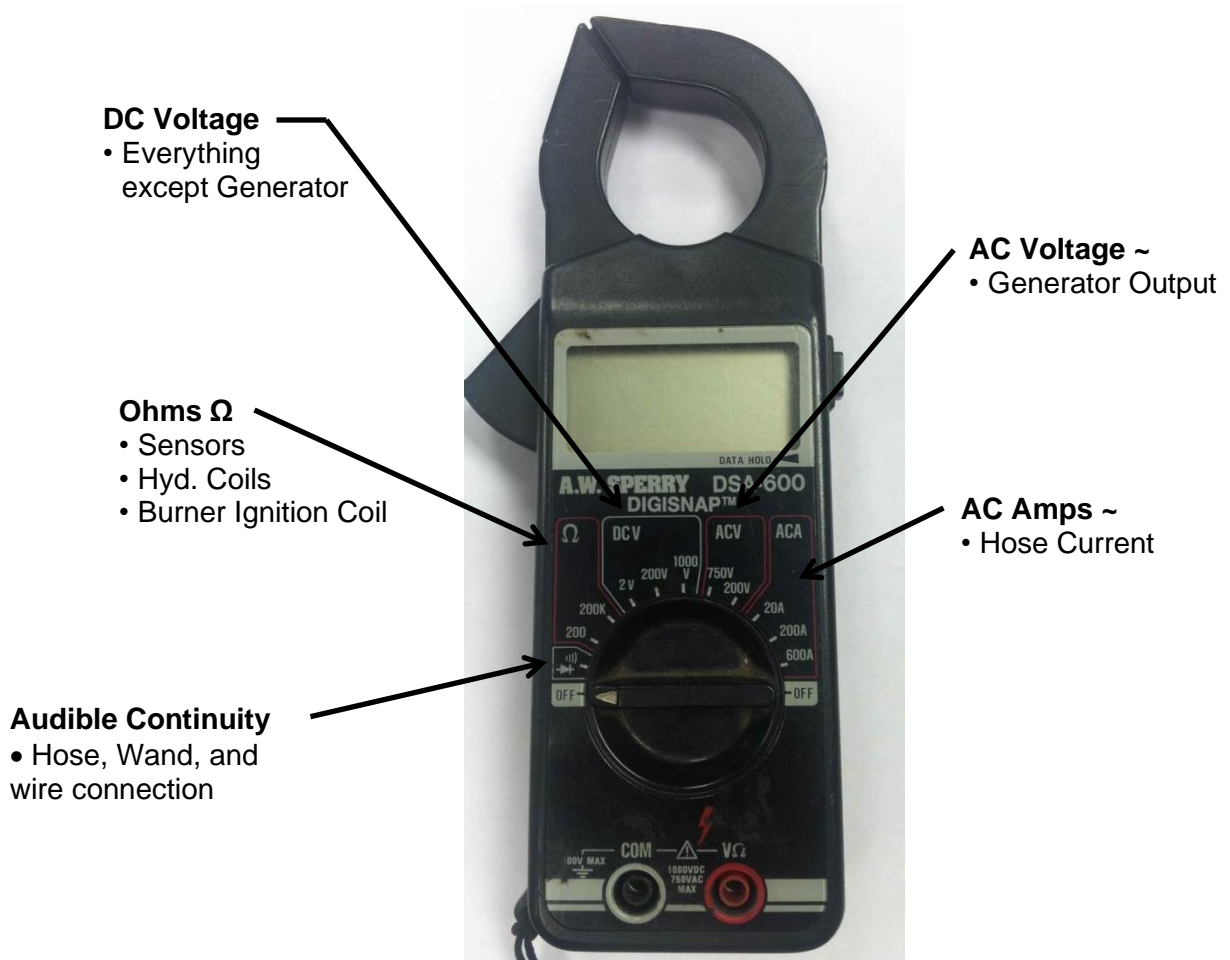

Fig. 7-2 Clamp-On Amp Meter/Multimeter

Chapter 8 Troubleshooting

8.0 Burner Troubleshooting

8.0.1. Symptoms: Burner will Not Ignite

Table 8-1 Basic Visual Burner Troubleshooting

Step	Possible Cause	If . . .
1	Start Troubleshooting at the control box. Is the diesel engine running?	<ul style="list-style-type: none"> • Yes, go to Step 2. • No, start the diesel engine. • Note: You can troubleshoot the burner without the engine running, but you must connect a battery charger to the battery and the ignition must be in the “ON” position.
2	Is the “MAIN POWER” toggle switch in the “ON” position?	<ul style="list-style-type: none"> • Yes, go to Step 3. • No, turn the toggle switch to the “ON” position.
3	Is the “BURNER” toggle switch in the “ON” position?	<ul style="list-style-type: none"> • Yes, go to Step 4. If this is a compressor the go to Step 3a. • No, turn the toggle switch to the “ON” position.
3a	Is the Main Power switch “ON”? NOTE: This step relates to compressor units only.	<ul style="list-style-type: none"> • Yes, go to Step 4. • No, turn “ON” the “Main Power” switch.
4	Are both the Material and Hot Oil temperature dials set to proper operating temperatures?	<ul style="list-style-type: none"> • Yes, go to Step 5. • No, set the Material according to the type of sealant you are using and the Hot Oil 100°F above the Material set point.
5	Are both the Material and Hot Oil temperature displays reading a three-digit positive number?	<ul style="list-style-type: none"> • Yes, go to Step 6. No, go to Table 8-3 Burner Electrical Troubleshooting. Step 2a.
6	Is the red "Burner" light "ON"?	<ul style="list-style-type: none"> • Yes, go to Step 7. • No, go to Table 8-3 Burner Electrical Troubleshooting. Step 5.
7	Is the “BURNER LOCKOUT” Alarm sounding?	<ul style="list-style-type: none"> • Yes, hold “BURNER RESET” switch down for 5 seconds. • No go to Step 8.
8	Are both the Material and Hot Oil temperature dials set above the current temperatures?	<ul style="list-style-type: none"> • Yes, go to Step 9. • No, set the Material temperature according to the type of material you are using and the Hot Oil 100°F above the Material set point.

Chapter 8 Troubleshooting

Table 8-2 Basic Visual Burner Troubleshooting (continued)

Step	Possible Cause	If . . .
9	Does either readout display a -1? NOTE: This occurs only when there is a short in the sensor circuit.	<ul style="list-style-type: none"> • Yes, this indicates a short in the circuit. Check the RTD sensor for water causing a short under the cap. Also look for worn wires possibly shorting to frame between sensor and control box. • No, go to step 9a.
9a	Does either readout display a 1? NOTE: This occurs only when the sensor circuit is not completed.	<ul style="list-style-type: none"> • Yes, this indicates a break in one or both of the sensor wires between the RTD sensor and the PAKSTAT. Check for broken wires between sensor and PAKSTAT. • No, go to Step 10.
10	Is the circuit breaker tripped?	<ul style="list-style-type: none"> • Yes, reset by pushing in the button that popped out. • No go to Step 11.
11	Is the fuel level low or empty?	<ul style="list-style-type: none"> • Yes, fill with #2 diesel fuel. Then bleed the burner, see Table 8-12 Bleeding the Diesel Burner. • No, go to Step 12.
12	Is there smoke coming out of the exhaust stack?	<ul style="list-style-type: none"> • Yes, go Table 8-7 Smoke Coming Out of Exhaust Stack. • No, go to Step 13.
13	Is your burner working properly, but it seems to take a while to reach operating temperature?	<ul style="list-style-type: none"> • Yes, go to Table 8-13 Sealant is Heating Slowly. • No, Call Crafco, Inc. and speak to a customer service technician.

Note: Use [Fig. 8-1 Diesel Burner Schematic](#) while troubleshooting the burner electrical system.

Chapter 8 Troubleshooting

Table 8-3 Burner Electrical Troubleshooting

Step	Possible Cause	If . . .
1	Is there 12Vdc between the “YEL-CHI-E” and “BLK” wires at the burner plug?	<ul style="list-style-type: none"> • Yes, go to Step 4. • No, go to Step 1a.
1a	Is there 12Vdc between the “YEL-CHI-E” wire on the burner relay in the control box and the “BLK-2” wire on the relay?	<ul style="list-style-type: none"> • Yes, check for poor connection or broken wire between the burner relay in the control box and the plug on the burner. • No, go to Step 1b.
1b	Is there 12Vdc between “WHT/RED-1” wire on the burner relay in the control box and the “BLK-2” wire on the relay?	<ul style="list-style-type: none"> • Yes, go to Step 2. • No, check for poor connection or broken wire between the burner relay in the control box and the burner reset switch.
2	Is there 12Vdc between the circuit breaker (red wire going to battery positive cable) and the ground lug on the battery tray?	<ul style="list-style-type: none"> • Yes, wait 15 seconds then repeat step 2. • If still no voltage then replace circuit breaker. • No, go to step 2a.
2a	Check for loose or broken wires between circuit breaker and battery positive cable.	<ul style="list-style-type: none"> • Yes, replace or repair damaged wire and repeat Step 3. • No, go to step 3.

Chapter 8 Troubleshooting

Table 8-4 Burner Electrical Trouble shooting (continued)

Step	Possible Cause	If . . .
3	Is there 12Vdc between the positive and negative battery post? If this check is done while the engine is running the reading should be 13.8 volts.	<ul style="list-style-type: none"> • Yes, then there should be 12Vdc on the battery side of the circuit breaker. • No, replace battery. • Note: If the reading is less than 13.8 volts while the engine is running the alternator needs to be rebuilt or replaced.
4	Is there 12Vdc between the “GRN-CH1-S” wire in the burner plug and the “BLK” wire in the burner plug?	<ul style="list-style-type: none"> • Yes, go to Table 8-9 Testing the DC Controller. • No, go to Step 4a.
4a	Is there 12Vdc between terminal #7 “GRN-CH1-S” on hot oil PAKSTAT and terminal #5 “BLK-1” wire of the oil PAKSTAT?	<ul style="list-style-type: none"> • Yes, check for loose or broken wires between burner plug and PAKSTAT. • No, go to Step 5.
5	Is there 12Vdc between terminal #6 “GRY-1” on hot oil PAKSTAT and terminal #5 “BLK-2” wire of the oil PAKSTAT	<ul style="list-style-type: none"> • Yes, replace hot oil PAKSTAT. • No, go to Step 5a.
5a	Is there 12Vdc between terminal #4 “GRY-1” wire on the material PAKSTAT and terminal #8 “BLK-2” wire of the material PAKSTAT	<ul style="list-style-type: none"> • Yes, check for loose or broken wires between hot oil PAKSTAT and the material PAKSTAT. • No, go to Step 6.
6	Is there 12Vdc between terminal #3 “ORN-1” wire and terminal #8 “BLK-2” wire of the material PAKSTAT?	<ul style="list-style-type: none"> • Yes, replace PAKSTAT. • No, go to Step 6a.
6a	Is there 12Vdc between terminal #9 “ORN-1” wire and terminal #8 “BLK-2” wire of the material PAKSTAT?	<ul style="list-style-type: none"> • Yes, replace PAKSTAT. • No, go to Step 6b.
6b	Is there 12Vdc between terminal #1 “ORN-1” wire and terminal #8 “BLK-2” wire of the material PAKSTAT?	<ul style="list-style-type: none"> • Yes, check for loose or broken wires between terminal #9 and #3 of material PAKSTAT. • No, go to Step 7.
7	Is there 12Vdc between terminal #3 “ORN-1” wire and terminal #5 “BLK-1” wire on hot oil PAKSTAT?	<ul style="list-style-type: none"> • Yes, check for loose or broken wires between terminal #3 of the hot oil PAKSTAT and terminal block. • No, go to Step 8.

Chapter 8 Troubleshooting

Table 8-5 Burner Electrical Trouble shooting (continued)

Step	Possible Cause	If . . .
8	Is there 12Vdc between bottom terminal "ORN-1" wire of burner ON/OFF toggle switch and nearby ground source (black wire)?	<ul style="list-style-type: none"> • Yes, check for loose or broken wires between top terminal power switch and terminal #3 of the hot oil PAKSTAT. • No, go to Step 9.
9	Is there 12Vdc between middle terminal "RED-3" wire of burner ON/OFF toggle switch and nearby ground source (black wire)?	<ul style="list-style-type: none"> • Yes, replace switch. • No, go to Step 10.
10	Is there 12Vdc between crank lock out relay middle terminal "RED-3" wire and "BLK-EH1" left terminal?	<ul style="list-style-type: none"> • Yes, check for loose or broken wires between the toggle switch and the relay. • No, go to Step 11.
11	Is there 12Vdc between crank lock out relay right terminal "TAN-EH4" wire and "BLK-EH1" left terminal?	<ul style="list-style-type: none"> • Yes, go to Step 12. • No, make sure the key switch is in the "ON" position.
12	Is there 12Vdc between crank lock out relay bottom terminal "RED-2" wire and "BLK-EH1" left terminal?	<ul style="list-style-type: none"> • Yes, replace switch. • No, go to Step 13.
13	Is there 12Vdc between the "Main Power Switch" "RED-2" wire and nearby ground source (black wire)?	<ul style="list-style-type: none"> • Yes, check for loose or broken wires between those two points. • No, go to Step 14.
14	Is there 12Vdc between the "Main Power Switch" "RED-1" wire and nearby ground source (black wire)?	<ul style="list-style-type: none"> • Yes, replace contact block. • No, go to Step 15.

Chapter 8 Troubleshooting

Table 8-6 Burner Electrical Troubleshooting (continued)

Step	Possible Cause	If . . .
15	Is there 12Vdc between top terminal of circuit breaker "RED-1" wire and nearby ground source (black wire)?	<ul style="list-style-type: none"> • Yes, check for loose or broken wires between top terminal of circuit breaker and bottom terminal (red wire) of power switch. • No, go to Step 16.
16	Is there 12Vdc between bottom terminal of circuit breaker "RED-EH1" wire and nearby ground source (black wire)?	<ul style="list-style-type: none"> • Yes, replace circuit breaker. • No, go to Step 17.
17	Is there 12Vdc between blue wire on starter solenoid and nearby ground source (black wire or bare metal on engine case)?	<ul style="list-style-type: none"> • Yes, check for loose or broken wire between starter solenoid and ignition switch. • No, go to step 18.
18	Check connections and condition of red battery cable.	<ul style="list-style-type: none"> • Yes, there should be 12Vdc at all previous steps. • No, replace battery cable.

Chapter 8 Troubleshooting

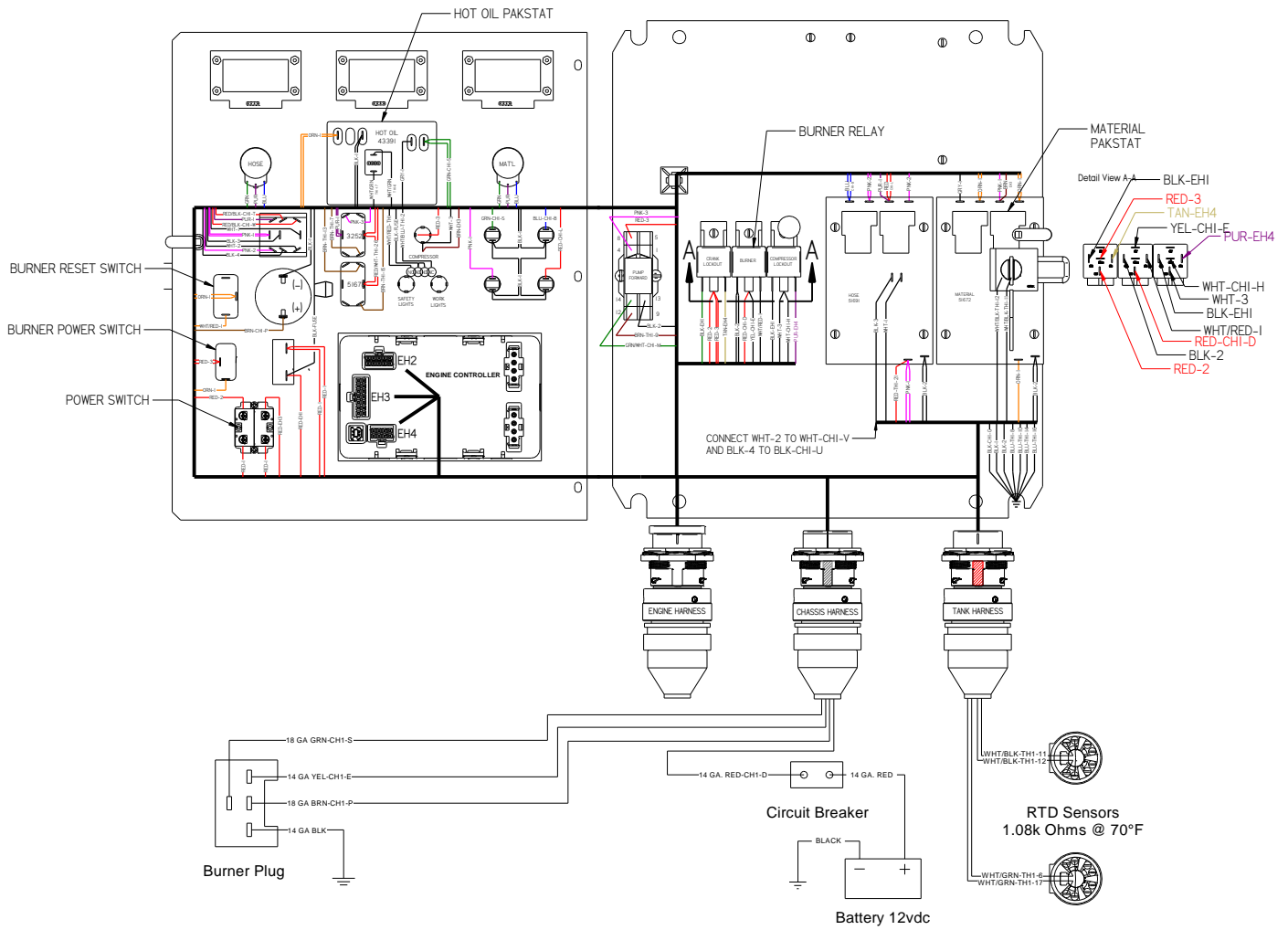

Fig. 8-1 Diesel Burner Schematic

Chapter 8 Troubleshooting

8.0.2. Excessive Smoke Coming Out of Exhaust Stack

Table 8-7 Smoke Coming Out of Exhaust Stack

Step	Smoke Coming Out of the Exhaust Stack
1	White smoke indicates that there is too much air being forced through the burner. Loosen the Air Shutter screw and rotate the Air Shutter counterclockwise to reduce air. Refer to Fig. 8-3 Diesel Burner Air Settings , for the proper air settings and diagram.
2	Black smoke indicates that there is not enough air being forced through the burner. First check the air settings, if more air is required rotate Air Shutter clockwise. Refer to Fig. 8-3 Diesel Burner Air Settings .
3	Refer to Fig. 8-3 Diesel Burner Air Settings to locate the following components. Using a 7/16" wrench, remove the copper fuel line nut attached to the nozzle line. Next remove the locking nut for the nozzle tube. Then loosen the locking tabs on the ignition coil and open the ignition coil. Remove the nozzle line assembly.
4	Using Fig. 8-2 Diesel Burner Electrode Adjustment , make sure the electrodes are in the correct position. Loosen the clamp holding the electrodes in place so they can be adjusted. Inspect the porcelain ceramic insulator for any cracks. Also check the tip of each of the electrodes to make sure they still have a sharp point and are not rounded off.
5	If it has been longer than 500 hours since the last time the burner nozzle was replaced, Crafco recommends replacing the burner nozzle at this time.
6	Reassemble the burner, using the reverse order in Step 3.
7	Remove the burner box assembly by removing the four (4) 1/2" bolts, flat washer, lock washer, and nuts holding the burner box onto the trailer.
7a	Make sure the insulation inside the burner box is not soaked with diesel fuel.
7b	If the insulation is soaked with diesel fuel, you will need to replace the insulation.
7c	Reassemble the burner box.

8.0.3. Burner Lights but Shuts Down After 15 Seconds

Table 8-8 Burner Lights but Shuts Down After 15 Seconds

Step	Possible Cause	If . . .
1	Does the CAD EYE have soot or dirt on the lens?	<ul style="list-style-type: none"> • Yes, clean cad eye lens with a soft cloth. No, go to Step 2.
2	Are the two yellow wires for the CAD EYE loose or broken?	<ul style="list-style-type: none"> • Yes, repair or replace as needed. No, go to Step 3.
3	Is the CAD EYE faulty?	<ul style="list-style-type: none"> • Yes, replace CAD EYE. No, call a Crafco Inc. service technician.

Chapter 8 Troubleshooting

8.0.4. Testing DC Controller

Table 8-9 Testing the DC Controller

Step	Bench Test DC Controller
1	Remove all wire nuts attaching the DC Controller to the burner.
2	Attach the black ground wire to the negative battery post.
3	Attach the red wire to the positive battery post.
4	Attach the white (Enable) wire to the positive battery post to start the test. (Genesis II Controllers will have a 15-second delay.) <ul style="list-style-type: none"> • Orange (Blower Motor) wire should have 12Vdc (all the time). • Blue (Igniter) wire should have 12Vdc.
5	Twist the yellow wires together (once voltage registers) on the orange, blue and purple wires. <ul style="list-style-type: none"> • Orange (Blower Motor) wire should maintain 12Vdc. • Blue (Igniter) wire should lose voltage after 15 seconds. • Purple (Valve) wire should maintain 12Vdc.
6	If any of the above tests fail, replace the DC Controller.

8.0.5. Burner Fuel Solenoid Testing

Table 8-10 Burner Fuel Solenoid Test

Step	Fuel Solenoid Test
1	Remove cord set from fuel solenoid.
2	Check the ohms between the terminals of fuel solenoid.
3	If the reading is between 15-25 ohms the coil is good.
4	If the reading is outside the above range or the meter indicates an open circuit, replace the fuel solenoid.

Chapter 8 Troubleshooting

8.0.6. Burner Ignition Coil Testing

Table 8-11 Burner Ignition Coil Test

Step	Ignition Coil Test
1	Make sure the burner is off. Open the ignition transformer (located above the blower) to expose the springs.
2	Check resistance between each of the springs and the ground (exposed metal on the burner).
3	The meter should read less than 2000 ohms. (Take note of the readings, you will use them in Step 5.)
4	Check resistance between both springs. (Take note of the reading, you will use it in Step 5.)
5	The igniter should be replaced if: <ul style="list-style-type: none"> • The difference between the two springs to ground resistance readings is greater than 20%. • Or the spring-to-spring resistance does not read approximately twice the spring to ground.

8.0.7. Bleeding the Burner

Table 8-12 Bleeding the Diesel Burner

Step	Bleeding the Diesel Burner
1	The burner is self-priming and will remove air bubbles automatically, however, if ever the need arises to perform a manual bleeding of the fuel line, place an oil pan under the machine in front of the burner.
2	Using a 3/8" wrench, loosen the bleeder valve on the fuel pump. Refer to Fig. 8-3 Diesel Burner Air Settings for bleeder location.
3	Turn the ignition key to the "ON" position, then turn the power toggle switch to the "ON" position. Fuel should flow out of the bleeder valve. You want the fuel to be clear from any air bubbles, this may require you to turn the ignition key "OFF" and "ON" a couple of times.
4	Allow burner to bleed itself until the fuel is clear of any bubbles.
5	Tighten the bleeder valve.
6	Turn off the power toggle switch and ignition key.

NOTE: The burner has been plumbed to have the burner be self-priming. Ensure the "Main Power" and "Burner" switch is "ON" and burner fuel pump will start circulating fuel through the fuel lines, which removes all air bubbles automatically, since it has a return line to the fuel tank.

Chapter 8 Troubleshooting

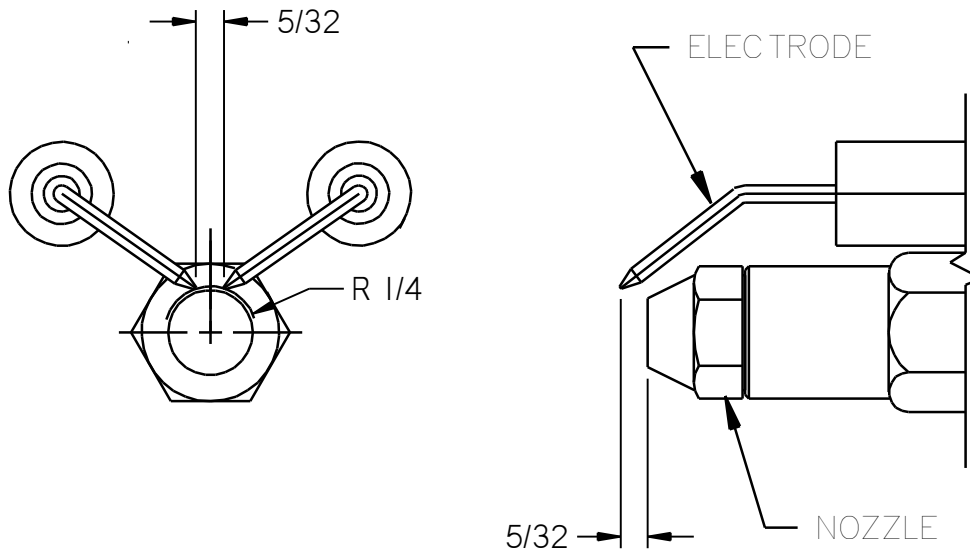

Fig. 8-2 Diesel Burner Electrode Adjustment

Air Shutter = 4
 Air Band = 4
 Fuel Pressure = 140 PSI
 Adjustment Plate = 3

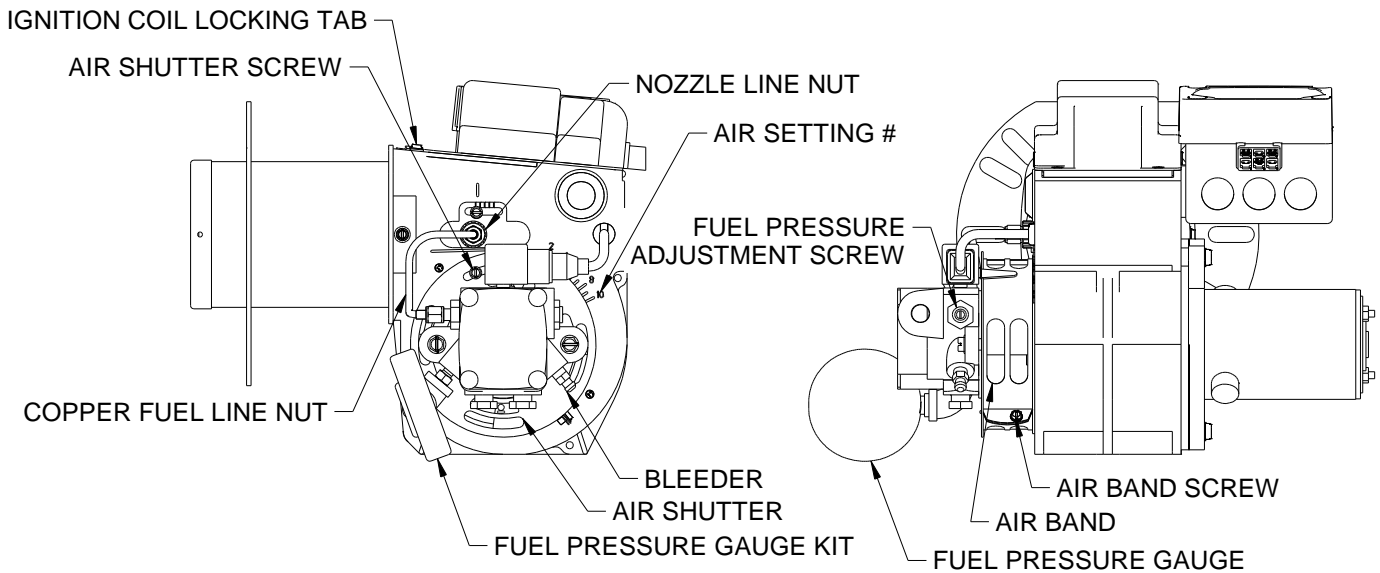

Fig. 8-3 Diesel Burner Air Settings

Chapter 8 Troubleshooting

8.1 Sealant is Heating Slowly

Table 8-13 Sealant is Heating Slowly

Step	Sealant is Heating Slowly
1	With the material level half or less, open the loading lid and inspect the inside edge of the material tank. Check if there is a buildup of old, dried out and hardened material along the top half of the material tank.
2	If this is the case you will need to drain out (use up) the rest of the material inside the tank. When the tank is empty, use an air chisel to remove this built up material. Remove as much as possible all around the tank including the roof of the material tank. Remove all the old sealant chunks from the bottom of the material tank. This should be done every year or as conditions require.
3	Check your level of the heat transfer oil, the mark on the dipstick is for 70°F.
4	Check your records of the last service replacement of the heat transfer oil. If it has been longer than 500 hours, or one year, you need to change your oil.
5	Many of Crafco, Inc. service centers can perform these service steps for you if you cannot. Call your local service center to find out if they can.

Chapter 8 Troubleshooting

8.2 Agitator Troubleshooting

8.2.1 Symptom: Mixer Does Not Rotate

Table 8-14 Basic Visual Mixer Troubleshooting

Step	Possible Cause	If . . .
1	Is the Material Temperature Display at or above 275°F?	<ul style="list-style-type: none"> • Yes, go to Step 2. • No, continue to allow the machine to heat. (Make sure the Material dial and the Hot Oil dial are set at operating temperatures.)
2	Is the red "Mixer" light "ON"?	<ul style="list-style-type: none"> • Yes, go to Step 4. • No, go to Table 8-15 Mixer Electrical Troubleshooting.
3	Is the loading door closed?	<ul style="list-style-type: none"> • Yes, go to Step 4. • No, shut the loading door.
4	Is the "Mixer" toggle switch in the "Forward" position?	<ul style="list-style-type: none"> • Yes, go to Step 5. • No, move the toggle switch to the forward position.
5	Move the "Mixer" toggle switch to the "Reverse" position. Is the agitator moving?	<ul style="list-style-type: none"> • Yes, allow mixer to reverse for 15 seconds and then move the "Mixer" toggle switch to the "Forward" position. Go to Step 6. • No, go to Table 8-15 Mixer Electrical Troubleshooting.
6	Open the Material loading door. Are there several unmelted blocks in the tank?	<ul style="list-style-type: none"> • Yes, this may cause the agitator to jam. Use the mixer toggle switch to move the agitator forward and backward until the material melts enough to allow forward movement without jamming. Crafco, Inc. recommends you add one to two blocks every three to four minutes during dispensing of product. • No, go to Table 8-15 Mixer Electrical Troubleshooting.
7	Is the hydraulic fluid level near the center of the sight gauge? Check at ambient temperature. See Fig. 5-1 Dipstick .	<ul style="list-style-type: none"> • Yes, go to Table 8-15 Mixer Electrical Troubleshooting. • No, fill oil to the center of the sight gauge.

Chapter 8 Troubleshooting

8.2.2 Mixer Electrical Troubleshooting

Note: Use [Table 8-15](#) while troubleshooting the mixer electrical system.

Table 8-15 Mixer Electrical Troubleshooting

Step	Possible Cause	If . . .
1	Is the amber light "ON" on the Din Plug when the "Mixer" toggle switch is in the "Forward" position? (For forward din plug location. Refer to Fig. 8-7 Din Plug Layout).	<ul style="list-style-type: none"> • Yes, then the mixer should be working. If it is not working see Table 8-17 Mixer Hydraulic Troubleshooting. • No, go to step 1a.
1a	Unscrew the din plug center screw so you can pull the din plug up about 1/4" in order to check for voltage. Is there 12Vdc from side post to side post?	<ul style="list-style-type: none"> • Yes, the electrical system for the agitator is working properly, go to Table 8-17 Mixer Hydraulic Troubleshooting. Also replace din plug at earliest convenience to retain visual troubleshooting ability. • No, go to step 2.
2	Is there 12Vdc between the "Mixer" toggle switch bottom post BRN-TH1-15 wire and nearby ground wire (blue wires)? (With the "Mixer" toggle switch in the "Forward" position.) Fig. 8-5 Mixer Circuit .	<ul style="list-style-type: none"> • Yes, replace din plug. • No, go to Step 2a.
2a	Is there 12Vdc between the "Mixer" toggle switch center post RED/WHT-TH1-26 wire and nearby ground source (blue wires)?	<ul style="list-style-type: none"> • Yes, replace mixer toggle switch. • No, go to step 3.
3	Is there 12Vdc between the lid switch RED/WHT-TH1-26 wire and a nearby ground source? (Check both RED/WHT-TH1-26 and RED-TH1-21 wires on the bottom of the lid switch with the lid closed.)	<ul style="list-style-type: none"> • Yes, on both red wires check for loose connections or broken wires between lid switch and mixer toggle switch. • Yes, on only one red wire when the lid is closed. Readjust the lid switch so that the lid completely depresses the switch, and then recheck for 12Vdc. If the same result happens, replace the lid switch. • No, go to Step 4.

Chapter 8 Troubleshooting

Table 8-16 Mixer Electrical Troubleshooting (continued)

Step	Possible Cause	If . . .
4	Check for 12Vdc at red wire labeled RED TH1-21 and pink wire labeled PNK-1 on the hose PAKSTAT terminal #9 and terminal #8 ground source (black wire)?	<ul style="list-style-type: none"> • Yes, on both, check for loose connections or broken wires between lid switch and hose board. • No, go to Step 4a.
4a	Is there 12Vdc between the Material PAKSTAT terminal #2 pink wire labeled PNK-1 and terminal #8 black ground wire? (Refer to Fig. 8-5 Mixer Circuit.)	<ul style="list-style-type: none"> • Yes, check for loose connections or broken wires between material PAKSTAT terminal #2 and hose PAKSTAT terminal #9. • No, go to Step 4b
4b	Is there 12Vdc between the Material PAKSTAT terminal #1 orange wire labeled ORN-1 and terminal #8 black ground wire?	<ul style="list-style-type: none"> • Yes, replace the Material PAKSTAT. • No, if this is the case then the diesel burner would not be working properly. Recheck the steps list above or contact a Crafco, Inc. customer service technician for help.

Chapter 8 Troubleshooting



Fig. 8-4 Checking Din Plug Voltage

Chapter 8 Troubleshooting

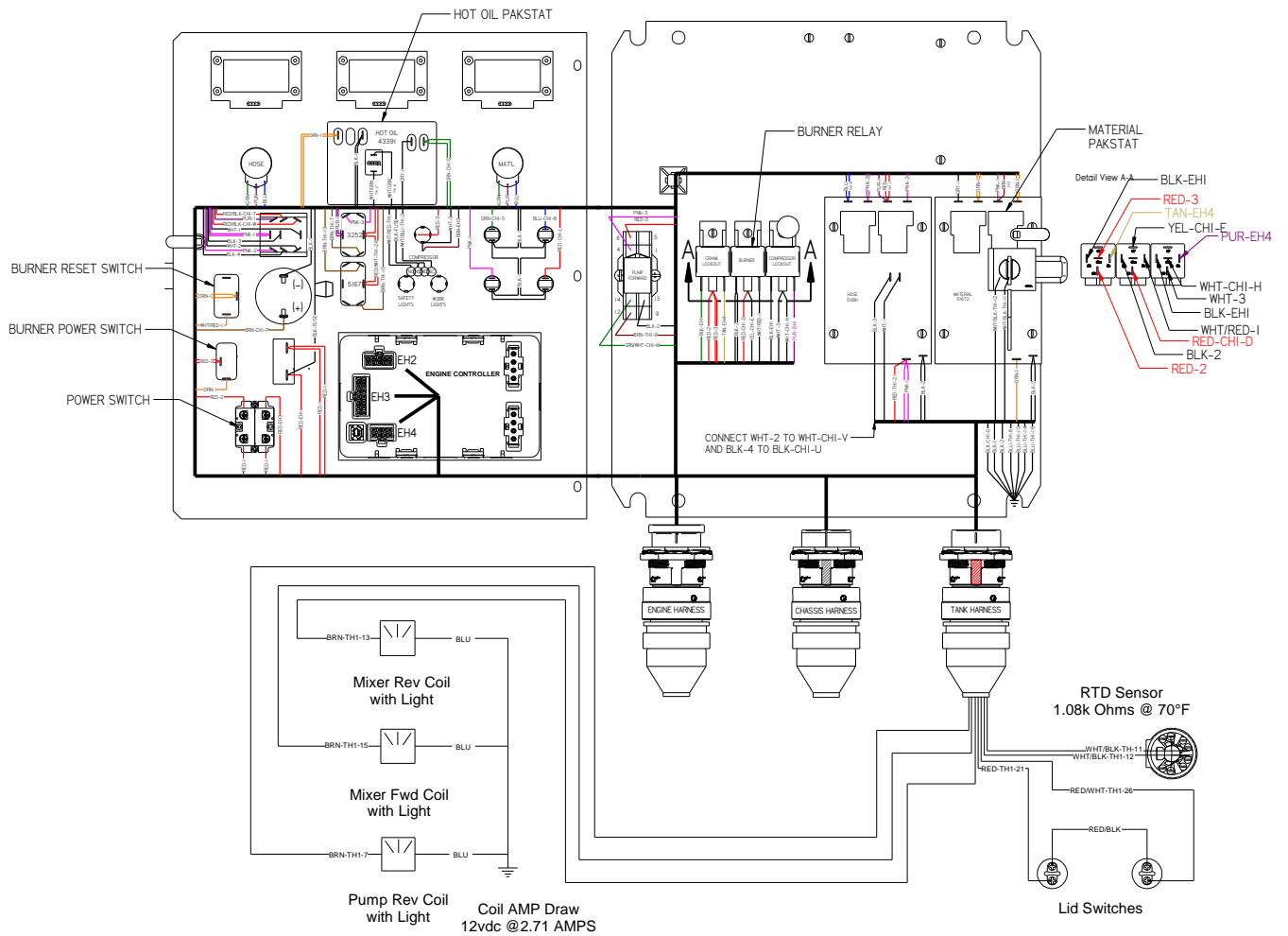

Chapter 8 Troubleshooting

8.2.3 Mixer Hydraulic Troubleshooting

Table 8-17 Mixer Hydraulic Troubleshooting

Step	Possible Cause	If . . .
1	Remove the din plug, then remove the coil by unscrewing the nut on top of the coil. With the coil removed, re-attach the din plug and energize the coil by moving the mixer switch to Forward or Reverse, then insert a screwdriver into the center of the coil. Does the coil magnetize when the din plug amber light is "ON"?	<ul style="list-style-type: none"> • Yes, go to Step 2. • No, replace the coil.
2	Is the relief pressure set correctly? (Refer to Fig. 8-6 Hydraulic Valve Pressure Setting , for pressure settings.)	<ul style="list-style-type: none"> • Yes, go to Step 3. • No, first turn "OFF" the Isuzu engine, then remove one of the two hydraulic hoses going to the agitator hydraulic motor, cap off the fitting on the motor and use a 3,000 PSI gauge with the proper JIC fitting, attach it to the hose. Start the Isuzu engine, turn "ON" the main power in the control box, move the "Mixer" toggle switch to the "Forward" position and read the pressure gauge. If the pressure needs to be adjusted use the pressure relief valve labeled "RVA", loosen the jam nut and adjust the pressure with the allen screw at the end of the relief. Turn clockwise to increase pressure and counterclockwise to decrease pressure, then tighten the jam nut to lock the pressure. Next turn "OFF" the Isuzu engine, remove the cap and pressure gauge, then re-attach the hose.
3	Is the hydraulic flow 1.5 GPM from the hydraulic valve? If you do not have a flow meter, call a local hydraulic shop to run the test for you.	<ul style="list-style-type: none"> • Yes, call Crafco, Inc. and speak to a customer service technician you should have been able to find the problem. • No, replace the flow divider in the hydraulic valve.
4	Is the hydraulic flow correct from the hydraulic pump? If you do not have a flow meter, call a local hydraulic shop to run the test for you. (Refer to Fig. 8-6 Hydraulic Valve Pressure Setting for flow rate).	<ul style="list-style-type: none"> • Yes, call Crafco, Inc. and speak to a customer service technician you should have been able to find the problem. • No, replace the hydraulic pump.

Chapter 8 Troubleshooting

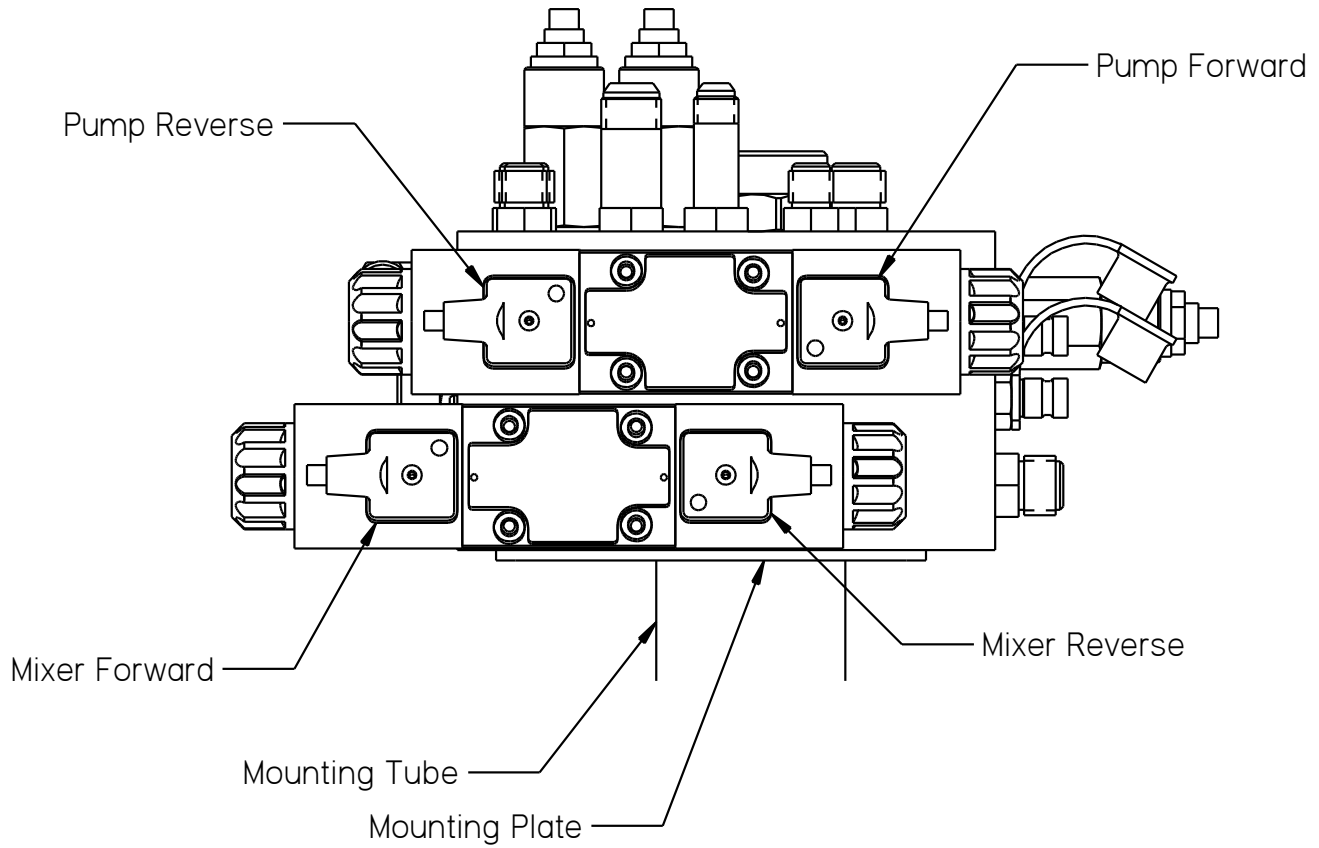

Fig. 8-7 Din Plug Layout

Chapter 8 Troubleshooting

8.3 Hose Troubleshooting

8.3.1 Symptom: Passenger Side Hose Does Not Heat

Table 8-18 Basic Visual Hose Troubleshooting

Step	Possible Cause	If . . .
1	Is the Material Temperature Display at or above 275°F?	<ul style="list-style-type: none"> • Yes, go to Step 2. • No, continue to allow the machine to heat. (Make sure the Material dial and the Hot Oil dial are set at operating temperatures.)
2	Is the red "HEATED HOSE" light "ON"?	<ul style="list-style-type: none"> • Yes, go to Table 8-19 Hose Electrical Troubleshooting. • No, allow the machine to heat material to 275°F.
2a	Is the circuit breaker tripped?	<ul style="list-style-type: none"> • Yes, reset the circuit breaker by pushing in the button which has popped out. • No, go to Table 8-19 Hose Electrical Troubleshooting.

NOTE: Use [Fig. 8-9 Hose Circuit Schematic](#) while troubleshooting the hose electrical system.

Table 8-19 Hose Electrical Troubleshooting

Step	Possible Cause	If . . .
1	Is there 12Vdc between "BATT" terminal of the generator and a nearby ground source (lug on battery tray)?	<ul style="list-style-type: none"> • Yes, go to Step 2. • No, go to Step 6.
2	Is there 24Vac between the white, green, and black wires? NOTE: Do this test inside the junction box. Check between black and white, black and green, and green and white.	<ul style="list-style-type: none"> • Yes, go to Step 3. • No, stop the engine, tighten the belt, restart engine and recheck output voltage. • Still no, replace the generator.
2a	Check the three heating element wires (blue) in the junction box for 30 Amps cold or 20-22 Amps hot. NOTE: Always use a clamp-on amp meter to perform this test. Each wire should have the same amp reading (+/- 1 amp).	<ul style="list-style-type: none"> • Yes, the hose should be working properly. • No, go to Step 3.

Chapter 8 Troubleshooting

Table 8-20 Hose Electrical Troubleshooting (continued)

Step	Possible Cause	If . . .
3	<p>Check for continuity in the hose from end to end. Disconnect the three blue heating element wires (blue) from the terminal block inside the junction box and disconnect the five pin plug between the hose and wand. Refer to Fig. 8-10 Junction Box Schematic.</p> <p>NOTE: Check each letter “D”, “E”, and “A” with the three blue wires on the other end of the hose. There should only be continuity on one wire to each letter.</p>	<ul style="list-style-type: none"> • Yes, go to Step 3a. • No, either there was no continuity from one letter to the other end of the hose or there was more than one wire with continuity to a letter. This hose needs to be repaired or replaced. Contact CrafcO, Inc. to send back the hose for repair.
3a	<p>Check the RTD sensor in the hose against the readout in the control box. Disconnect the black and white wires from the terminal block in the junction box and test for ohms. Refer to Table 8-23 RTD Sensor Ohms vs. Temperature.</p>	<ul style="list-style-type: none"> • Yes, the readout matches the table, go to Step 4. • No, this hose needs to be repaired or replaced. Contact CrafcO, Inc. to send back the hose for repair.
4	<p>Check for continuity in the wand between “D”, “E”, and “A”.</p> <p>NOTE: Check between “D” and “E”, “D” and “A”, and “A” and “E”.</p>	<ul style="list-style-type: none"> • Yes, go to Step 5. • No, this wand needs to be repaired or replaced. Contact CrafcO, Inc. to send back the wand for repair.
5	<p>Is there 12Vdc between wire labeled “BLU-GEN” on the upper terminal block and nearby ground source (black wire)?</p>	<ul style="list-style-type: none"> • Yes, check for loose or broken connections between terminal block “BATT” terminal of generator. • No, go to Step 6.
6	<p>Is there 12Vdc between Hose PAKSTAT blue wire terminal #4 and black wire terminal #8?</p>	<ul style="list-style-type: none"> • Yes, check for loose or broken wire between terminal #4 and the terminal block. • No, go to Step 6a.
6a	<p>Is there 12Vdc between Hose PAKSTAT terminal #3 Pink wire and terminal #8 black wire?</p>	<ul style="list-style-type: none"> • Yes, replace hose PAKSTAT. • No, go to Step 6b.
6b	<p>Is there 12Vdc between Hose PAKSTAT pink wire terminal #1 and black wire terminal #8?</p>	<ul style="list-style-type: none"> • Yes, check for loose or broken wires between terminal #1 and terminal #3. • No, go to Step 7.
7	<p>Is there 12Vdc between pink wire labeled “PNK-1 on the upper terminal block and a nearby ground source (black wire)?</p>	<ul style="list-style-type: none"> • Yes, check for loose or broken wire between terminal block and terminal #1. • No go to Step 7a.
7a	<p>Is there 12Vdc between pink wire labeled “PNK-4 and nearby ground source (black wire)?</p>	<ul style="list-style-type: none"> • Yes, replace terminal block. • No, go to Step 8.

Chapter 8 Troubleshooting

Table 8-21 Electrical Troubleshooting (continued)

Step	Possible Cause	If . . .
8	Is there 12Vdc between the Hose Selector switch pink wire labeled "PNK-4 (bottom left terminal) and a near" ground source black wire?	<ul style="list-style-type: none"> • Yes, check for loose or broken wires between switch and upper terminal block. • No, go to Step 8a.
8a	Is there 12Vdc between the Hose Selector switch pink wire Labeled "PNK-3" center left terminal and a nearby ground source.	<ul style="list-style-type: none"> • Yes, replace Hose Selector switch. • No, go to Step 9.
9	Is there 12Vdc between pink wire labeled "PNK-3 on the upper terminal block and a nearby ground source black wire?	<ul style="list-style-type: none"> • Yes, check for loose or broken wire between terminal block and hose selector switch. • No go to Step 9a.
9a	Is there 12Vdc between pink wire labeled "PNK-2" on upper terminal block and nearby ground source black wire?	<ul style="list-style-type: none"> • Yes, replace terminal block. • No, go to Table 8-16 Mixer Electrical Troubleshooting (continued) Steps 4a through 10a.

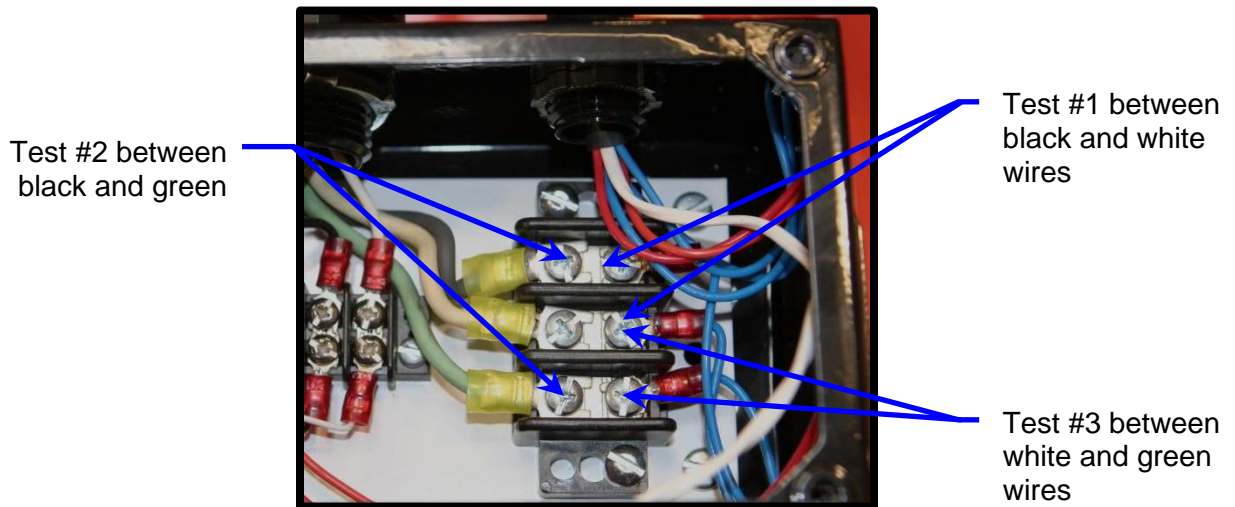

Fig. 8-8 Junction Box Voltage Testing

Chapter 8 Troubleshooting

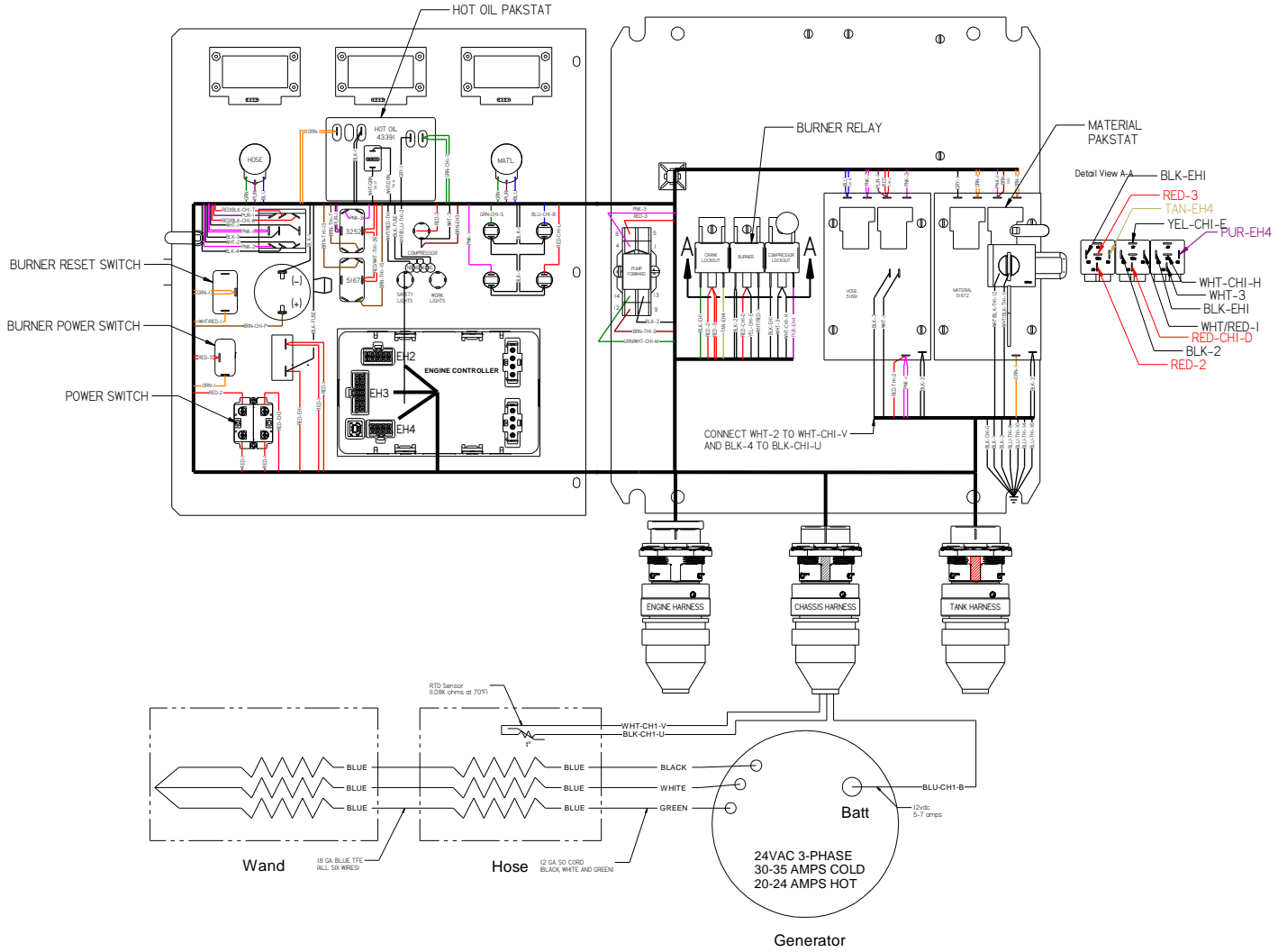

Fig. 8-9 Hose Circuit Schematic

Chapter 8 Troubleshooting

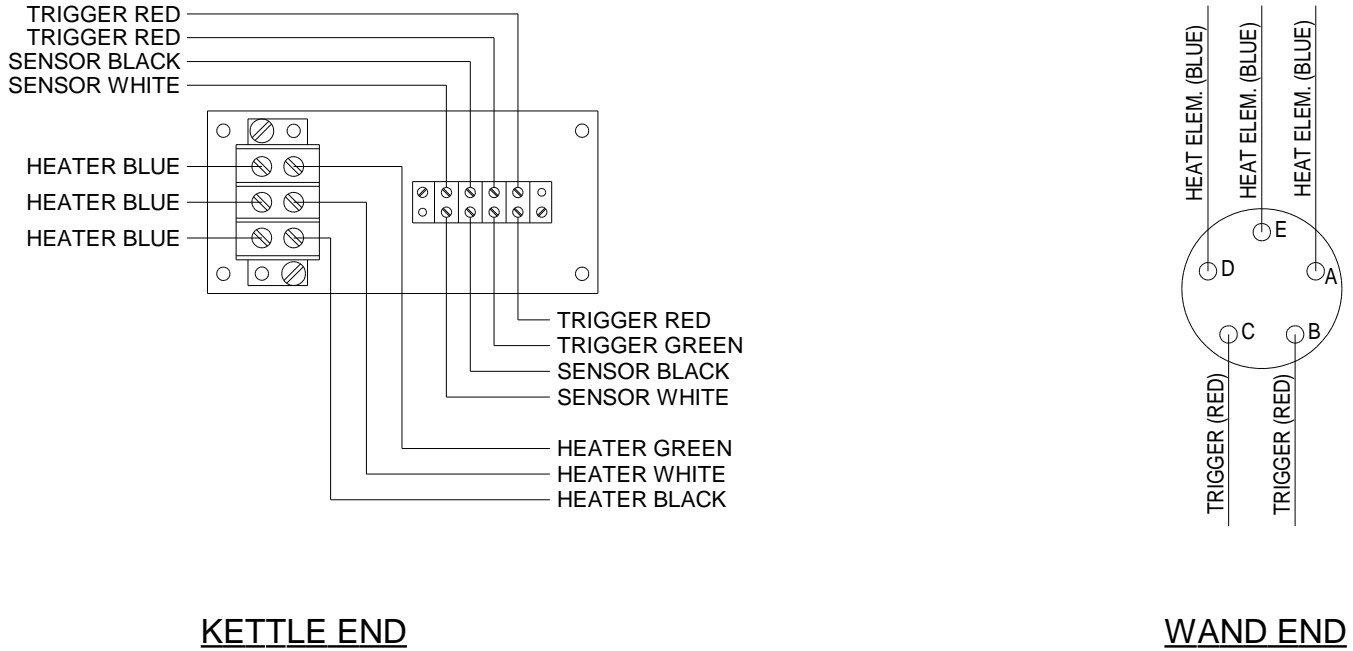

Fig. 8-10 Junction Box Schematic

Chapter 8 Troubleshooting

8.3.2 Symptom: Trigger is not Working

Table 8-22 Trigger is Not Working

Step	Possible Cause	If . . .
1	Check continuity between two red wires coming from the hose in junction box. NOTE: These wires must be disconnected from the terminal block and the trigger depressed to perform this test.	<ul style="list-style-type: none"> • Yes, go to Table 8-25 Basic Visual Pump Troubleshooting. • No, go to Step 2.
2	Disconnect the electrical connector between the hose and wand, check for continuity between C and B wand side.	<ul style="list-style-type: none"> • Yes, this hose needs to be repaired or replaced. Contact Crafco, Inc. to send back the hose for repair. • No, this wand needs to be repaired or replaced. Contact Crafco, Inc. to send back the hose for repair.

Chapter 8 Troubleshooting

8.3.3 RTD Sensor Ohms vs. Temperature

Table 8-23 below shows what the ohm reading would be for a given temperature. The following are the instructions for using the table.

Measure the resistance (ohms) of the sensor in question with an ohm meter (See [7.3 Checking Resistance \(Ohms\)](#)) in Section [7.0 How to Use a Multimeter](#).

Find the reading in the chart (columns 0 through 9).

Follow the row to the left and get the temperature in 10°F increments, then follow the column up to get the 1°F increment. (For example, 1391 Ohms = 215°F)

Table 8-23 RTD Sensor Ohms vs. Temperature

°F	0	1	2	3	4	5	6	7	8	9
0	930.3	932.5	934.7	936.9	939.1	941.3	943.4	945.6	947.8	950.0
10	952.2	954.3	956.5	958.7	960.9	963.0	965.2	967.4	969.6	971.8
20	973.9	976.1	978.3	980.5	982.6	984.8	987.0	989.1	991.3	993.5
30	995.7	997.8	1000.0	1002.2	1004.3	1006.5	1008.7	1010.9	1013.0	1015.2
40	1017.4	1019.5	1021.7	1023.9	1026.0	1028.2	1030.4	1032.5	1034.7	1036.9
50	1039.0	1041.2	1043.4	1045.5	1047.7	1049.8	1052.0	1054.2	1056.3	1058.5
60	1060.7	1062.8	1065.0	1067.1	1069.3	1071.5	1073.6	1075.8	1077.9	1080.1
70	1082.2	1084.4	1086.6	1088.7	1090.9	1093.0	1095.2	1097.3	1099.5	1101.6
80	1103.8	1106.0	1108.1	1110.3	1112.4	1114.6	1116.7	1118.9	1121.0	1123.2
90	1125.3	1127.5	1129.6	1131.8	1133.9	1136.1	1138.2	1140.4	1142.5	1144.7
100	1146.8	1149.0	1151.1	1153.2	1155.4	1157.5	1159.7	1161.8	1164.0	1166.1
110	1168.3	1170.4	1172.5	1174.7	1176.9	1179.0	1181.1	1183.3	1185.4	1187.5
120	1189.7	1191.8	1194.0	1196.1	1198.2	1200.4	1202.5	1204.6	1206.8	1208.9
130	1211.0	1213.2	1215.3	1217.5	1219.6	1221.7	1223.9	1226.0	1228.1	1230.3
140	1232.4	1234.5	1236.7	1238.9	1240.9	1243.0	1245.2	1247.3	1249.4	1251.6
150	1253.7	1255.8	1258.0	1260.1	1262.2	1264.3	1266.5	1268.6	1270.7	1272.8
160	1275.0	1277.1	1279.2	1281.3	1283.5	1285.6	1287.7	1289.8	1292.0	1294.1
170	1296.2	1298.3	1300.4	1302.6	1304.7	1306.8	1308.9	1311.0	1313.2	1315.3
180	1317.4	1319.5	1321.6	1323.8	1325.9	1328.0	1330.1	1332.2	1334.3	1336.5
190	1338.6	1340.7	1342.8	1344.9	1347.0	1349.1	1351.2	1353.4	1355.5	1357.6
200	1359.7	1361.8	1363.9	1366.0	1368.1	1370.2	1372.4	1374.5	1376.6	1378.7
210	1380.8	1382.9	1385.0	1387.1	1389.2	1391.3	1393.4	1395.5	1397.6	1399.7
220	1401.8	1403.9	1406.0	1408.1	1410.3	1412.4	1414.5	1416.6	1418.7	1420.8
230	1422.9	1425.0	1427.1	1429.2	1431.3	1433.4	1435.5	1437.6	1439.6	1441.7
240	1443.8	1445.9	1448.0	1450.1	1452.2	1454.3	1456.4	1458.5	1460.6	1462.7
250	1464.8	1466.9	1469.0	1471.1	1473.2	1475.3	1477.3	1479.4	1481.5	1483.6
260	1485.7	1487.8	1489.9	1492.0	1494.1	1496.1	1498.2	1500.3	1502.4	1504.5

Chapter 8 Troubleshooting

Table 8-24 RTD Sensor Ohms vs. Temperature (continued)

°F	0	1	2	3	4	5	6	7	8	9
270	1506.6	1508.7	1510.8	1512.8	1514.9	1517.0	1519.1	1521.2	1523.3	1525.3
280	1527.4	1529.5	1531.6	1533.7	1535.7	1537.8	1539.9	1542.0	1544.1	1546.1
290	1548.2	1550.3	1552.4	1554.5	1556.5	1558.6	1560.7	1562.8	1564.8	1566.9
300	1569.0	1571.1	1573.1	1575.2	1577.3	1579.4	1581.4	1583.5	1585.6	1587.7
310	1589.7	1591.8	1593.9	1595.9	1598.0	1600.1	1602.2	1604.2	1606.3	1608.4
320	1610.4	1612.5	1614.6	1616.6	1618.7	1620.8	1622.8	1624.9	1627.0	1629.0
330	1631.1	1633.2	1635.2	1637.3	1639.3	1641.4	1643.5	1645.5	1647.6	1649.7
340	1651.7	1653.8	1655.8	1657.9	1660.0	1662.0	1664.1	1666.1	1668.2	1670.2
350	1672.3	1674.4	1676.4	1678.5	1680.5	1682.6	1684.6	1686.7	1688.7	1690.8
360	1692.9	1694.9	1697.0	1699.0	1701.1	1703.1	1705.2	1707.2	1709.3	1711.3
370	1713.4	1715.4	1717.5	1719.5	1721.6	1723.6	1725.7	1727.7	1729.8	1731.8
380	1733.9	1735.9	1737.9	1740.0	1742.0	1744.1	1746.1	1748.2	1750.2	1752.3
390	1754.3	1756.3	1758.4	1760.4	1762.5	1764.5	1766.6	1768.6	1770.6	1772.7
400	1774.7	1776.8	1778.8	1780.8	1782.9	1784.9	1786.9	1789.0	1791.0	1793.1
410	1795.1	1797.1	1799.2	1801.2	1803.2	1805.3	1807.3	1809.3	1811.4	1813.4
420	1815.4	1817.5	1819.5	1821.5	1823.6	1825.6	1827.6	1829.6	1831.7	1833.7
430	1835.7	1837.8	1839.8	1841.8	1843.8	1845.9	1847.9	1849.9	1851.9	1854.0
440	1856.0	1858.0	1860.0	1862.1	1864.1	1866.1	1868.1	1870.2	1872.2	1874.2
450	1876.2	1878.2	1880.3	1882.3	1884.3	1886.3	1888.3	1890.4	1892.4	1894.4
460	1896.4	1898.4	1900.5	1902.5	1904.5	1906.5	1908.5	1910.5	1912.6	1914.6
470	1916.6	1918.6	1920.6	1922.6	1924.6	1926.6	1928.7	1930.7	1932.7	1934.7
480	1936.7	1938.7	1940.7	1942.7	1944.7	1946.8	1948.8	1950.8	1952.8	1954.8
490	1956.8	1958.8	1960.8	1962.8	1964.8	1966.8	1968.8	1970.8	1972.8	1974.8
500	1976.8	1978.8	1980.8	1982.9	1984.9	1986.9	1988.9	1990.9	1992.9	1994.9
510	1996.9	1998.9	2000.9	2002.9	2004.9	2006.9	2008.8	2010.8	2012.8	2014.8
520	2016.8	2018.8	2020.8	2022.8	2024.8	2026.8	2028.8	2030.8	2032.8	2034.8
530	2036.8	2038.8	2040.8	2042.8	2044.7	2046.7	2048.7	2050.7	2052.7	2054.7
540	2056.7	2058.7	2060.7	2062.7	2064.6	2066.6	2068.6	2070.6	2072.6	2074.6
550	2076.6	2078.5	2080.5	2082.5	2084.5	2086.5	2088.5	2090.4	2092.4	2094.4

Chapter 8 Troubleshooting

8.4 Pump Troubleshooting

8.4.1 Symptom: Material Does Not Dispense When the Pump is Activated

Table 8-25 Basic Visual Pump Troubleshooting

Step	Possible Cause	If . . .
1	Is the Hose Temperature Display at or above 325°F?	<ul style="list-style-type: none"> • Yes, go to Step 2. • No, continue to allow the hose to heat. (Make sure the Hose dial is set at proper operating temperature.)
2	Is the red "Pump" light "ON"?	<ul style="list-style-type: none"> • Yes, go to Step 3. • No, go to Table 8-26 Pump Electrical Troubleshooting.
3	Is the hose selector switch in the "ELECTRIC" position as well as the pump switch should be in "ON ELECTRIC" position?	<ul style="list-style-type: none"> • Yes, go to Step 4. • No, move the toggle switches to the proper positions.
4	With the wand in the shoebox, pull the wand trigger and look at the material pump shaft coupler. Is it spinning clockwise?	<ul style="list-style-type: none"> • Yes, shut down machine and look for a plug in the plumbing. • No, adjust the material flow control to increase the flow. • Still no, go to Step 5.
5	Inside the control box and under the front panel, find the relay cube for the pump. It is found near the middle, left-hand side of the box. It is a clear yellow cube with a green button facing the top of the control box. When the trigger is engaged does the green light illuminate?	<ul style="list-style-type: none"> • Yes, this indicates that 12Vdc is reaching the relay coil. Go to Table 8-27 Pump Electrical Troubleshooting (continued) Step 5 to find the problem. • No, go to Table 8-26 Pump Electrical Troubleshooting, Steps 2 to find the problem.
6	Is the hydraulic fluid level near the center of the sight gauge when the machine is cold? See Fig. 5-1 Dipstick .	<ul style="list-style-type: none"> • Yes, go to Table 8-26 Pump Electrical Troubleshooting. • No, fill oil to the center of the sight gauge.

Chapter 8 Troubleshooting

NOTE: Use [Fig. 8-11 Pump Circuit Schematic](#) while troubleshooting the pump electrical system.

Table 8-26 Pump Electrical Troubleshooting

Step	Possible Cause	If . . .
1	Is the Hose Temperature at or above 325°F?	<ul style="list-style-type: none"> • Yes go to Step 2. • No, continue to allow the machine to heat.
2	Is there 12 Vdc between the Hose PAKSTAT terminal #2 red and redCH1-L wire and terminal #8 blk-2 ground wire? (Refer to the pump circuit schematic Fig. 8-11 Pump Circuit Schematic)	<ul style="list-style-type: none"> • Yes, go to Step 3. • No, go to Step 2a.
2a	Is there 12 Vdc between the Hose PAKSTAT terminal #1 pink wire and terminal #8 blk-2 ground wire?	<ul style="list-style-type: none"> • Yes, check for a broken wire or poor wire crimp on the terminal #2 red and redCH1-L wire and recheck for 12 Vdc. (If still no voltage, replace the Material PAKSTAT.) • No, go to Step 2b.
2b	Is there 12 Vdc between the Hose PAKSTAT terminal #9 pink wire and terminal #8 blk-2 ground wire?	<ul style="list-style-type: none"> • Yes, check for a broken wire or poor wire crimp on terminal #1 pink wire. (If you have 12 Vdc on terminal #9 pink then you must have 12 Vdc on terminal #1 pink wire; they are the same wire.) • No, If this is the case you would have had a hose heating issue.
3	Move to the junction box at the rear of the machine and open the cover. Is there 12 Vdc between the trigger red wire coming from the control box and a nearby ground source?	<ul style="list-style-type: none"> • Yes, go to Step 3a. • No, check for a broken wire or poor wire crimp between the junction box and the control box red wire labeled red-trig.
3a	Is there 12 Vdc between the trigger red wire going toward the hose (just above where you checked in Step 4) and a nearby ground source?	<ul style="list-style-type: none"> • Yes go to Step 3b. • No, check for a broken wire or poor wire crimp on the red trigger going toward the hose.

Chapter 8 Troubleshooting

Table 8-27 Pump Electrical Troubleshooting (continued)

Step	Possible Cause	If . . .
3b	<p>Is there 12 Vdc between the trigger red wire going toward the hose and a nearby ground source?</p> <p>(Make sure the wand trigger is pulled during this Step.)</p>	<ul style="list-style-type: none"> • Yes, go to Step 3c. • No, go to Step 4.
3c	<p>Is there 12 Vdc between the trigger green/white-CH1-M wire coming from the control box and a nearby ground source?</p> <p>(Make sure the wand trigger is pulled during this Step.)</p>	<ul style="list-style-type: none"> • Yes, go to Step 5. • No, check for a broken wire or poor wire crimp on the green trigger wire going to the control box.
4	<ul style="list-style-type: none"> • Disconnected the five-pin connector between the hose and wand. Refer to Fig. 8-10 Junction Box Schematic. <p>Is there continuity on the wand connector between red trigger "C" post and red trigger "B" post while the wand trigger is pulled?</p>	<ul style="list-style-type: none"> • Yes, go to Step 4a. • No, call Crafcro, Inc. and request an RA # so you can send your wand back for repair.
4a	<p>Disconnect the two red trigger wires in the junction box going toward the hose. Move the wand end of the hose next to the junction box.</p> <p>Is there continuity on the hose connector "C" socket and only one red trigger in the junction box?</p> <p>(Check both red trigger wires in the junction box one at a time.)</p>	<ul style="list-style-type: none"> • Yes, go to Step 4b. • No, recheck the hose connector "C" socket to the other red trigger wire in the junction box. (You want to see continuity between only one red trigger wire and the "C" socket.) • Still no or continuity to both red trigger wire, then call Crafcro, Inc. and request an RA# so you can send your hose back for repair.
4b	<p>Is there continuity on the hose connector "B" socket and red trigger in the junction box?</p>	<ul style="list-style-type: none"> • Yes, call Crafcro, Inc. and speak to a service technician, you should have found the problem. • No, recheck the hose connector "B" socket to the other red trigger wire in the junction box. (You want to see continuity between only one red trigger wire and the "B" socket.) • Still no or continuity to both red trigger wire, then call Crafcro, Inc. and request an RA# so you can send your hose back for repair.

Chapter 8 Troubleshooting

Table 8-28 Pump Electrical Troubleshooting (continued)

Step	Possible Cause	If . . .
5	Move back to the control box. Is there 12 Vdc between the pump relay base #14 terminal green/white-CH1-M trigger wire and the #13 terminal blk-2 ground wire, when the trigger is pulled?	<ul style="list-style-type: none"> • Yes, go to Step 6. • No, check for a broken wire or loose wire at the relay base on both the green trigger wire and the two black ground wires. Also check for any damage to the green/white-CH1-M trigger wire from the junction box to the control box.
6	Is there 12 Vdc between the pump relay base #12 terminal red-3 wire and the #13 terminal blk-2 ground wire?	<ul style="list-style-type: none"> • Yes, go to Step 7. • No, go to Step 6a.
6a	Is there 12 Vdc between the circuit breaker bottom post red-3 wire and the pump relay base #13 terminal blk-2 ground wire?	<ul style="list-style-type: none"> • Yes, check for a broken wire or loose wire at the circuit breaker and at the terminal block red wire. • No, if this is the case you would have had problems with the burner working. Call Crafco, Inc. and speak to a service technician.
7	Is there 12 Vdc between the pump relay base #8 terminal brn-TH1-9 pump wire and the #13 terminal blk-2 ground wire?	<ul style="list-style-type: none"> • Yes, go to Step 8. • No, replace the pump relay cube.
8	Move to the rear of the machine. Remove the cover over the hydraulic manifold. Is the amber light "ON" when the wand trigger is pulled? (Looking down at the top of the hydraulic valve, Pump forward is the din plug lower right-hand corner, Refer to Fig. 8-7 Din Plug Layout.)	<ul style="list-style-type: none"> • Yes, go to Step 9. • No, go to Step 8a.

Chapter 8 Troubleshooting

Table 8-29 Pump Electrical Troubleshooting (continued)

Step	Possible Cause	If . . .
8a	Unscrew the din plug center screw so you can pull the din plug up about 1/4", so you can check for voltage. Is there 12 Vdc from side post to side post, when the wand trigger is pulled?	<ul style="list-style-type: none"> • Yes, the electrical system for the agitator is working properly, go to Table 8-30 Hydraulic Troubleshooting. • No, recheck the amber light, if the light comes "ON" and you do not have 12 Vdc then replace the din plug.
9	Does the hydraulic pump shaft coupler turn counterclockwise, when you hold the "Pump" toggle switch in the "Reverse" position?	<ul style="list-style-type: none"> • Yes, this feature is working properly. • No, go to Step 9a.
9a	Is the amber light "ON" when you hold the "Pump" toggle switch in the "Reverse" position? (Looking down at the top of the hydraulic valve, Pump reverse is the din plug lower left-hand corner, Refer to Fig. 8-7 Din Plug Layout)	<ul style="list-style-type: none"> • Yes, go to Step 9e. • No, go to Step 9b.
9b	<ul style="list-style-type: none"> • Is there 12 Vdc between the "Pump" toggle switch bottom post brn-TH1-7 wire and the blue (4) wires ground din plug, when the toggle switch is in the "Reverse" position? (Refer to Fig. 8-7 Din Plug Layout.) 	<ul style="list-style-type: none"> • Yes, go to Step 9e. • No, go to Step 9c.
9c	Is there 12 Vdc between the "Pump" toggle switch center post red-TH1-26 wire and the blue (4) wires ground dinplug?	<ul style="list-style-type: none"> • Yes, replace the toggle switch. • No, go to Step 9d.
9d	Is there 12 Vdc between the "Mixer" toggle switch center post red-TH1-26 wire and the blue (4) wires ground dinplug?	<ul style="list-style-type: none"> • Yes, check for a broken wire or poor wire crimp on the red wire between the "Mixer" toggle switch and the "Pump" toggle switch. • No, if this is the case you would have had an agitator problem. Call Crafco, Inc. and speak to a service technician.
9e	Unscrew the din plug center screw so you can pull the din plug up about 1/4", so you can check for voltage. Is there 12 Vdc from side post to side post, when the wand trigger is pulled?	<ul style="list-style-type: none"> • Yes, the electrical system for the agitator is working properly, go to Table 8-30 Hydraulic Troubleshooting. • No, recheck the amber light, if the light comes "ON" and you do not have 12 Vdc then replace the din plug.

Chapter 8 Troubleshooting

Fig. 8-11 Pump Circuit Schematic

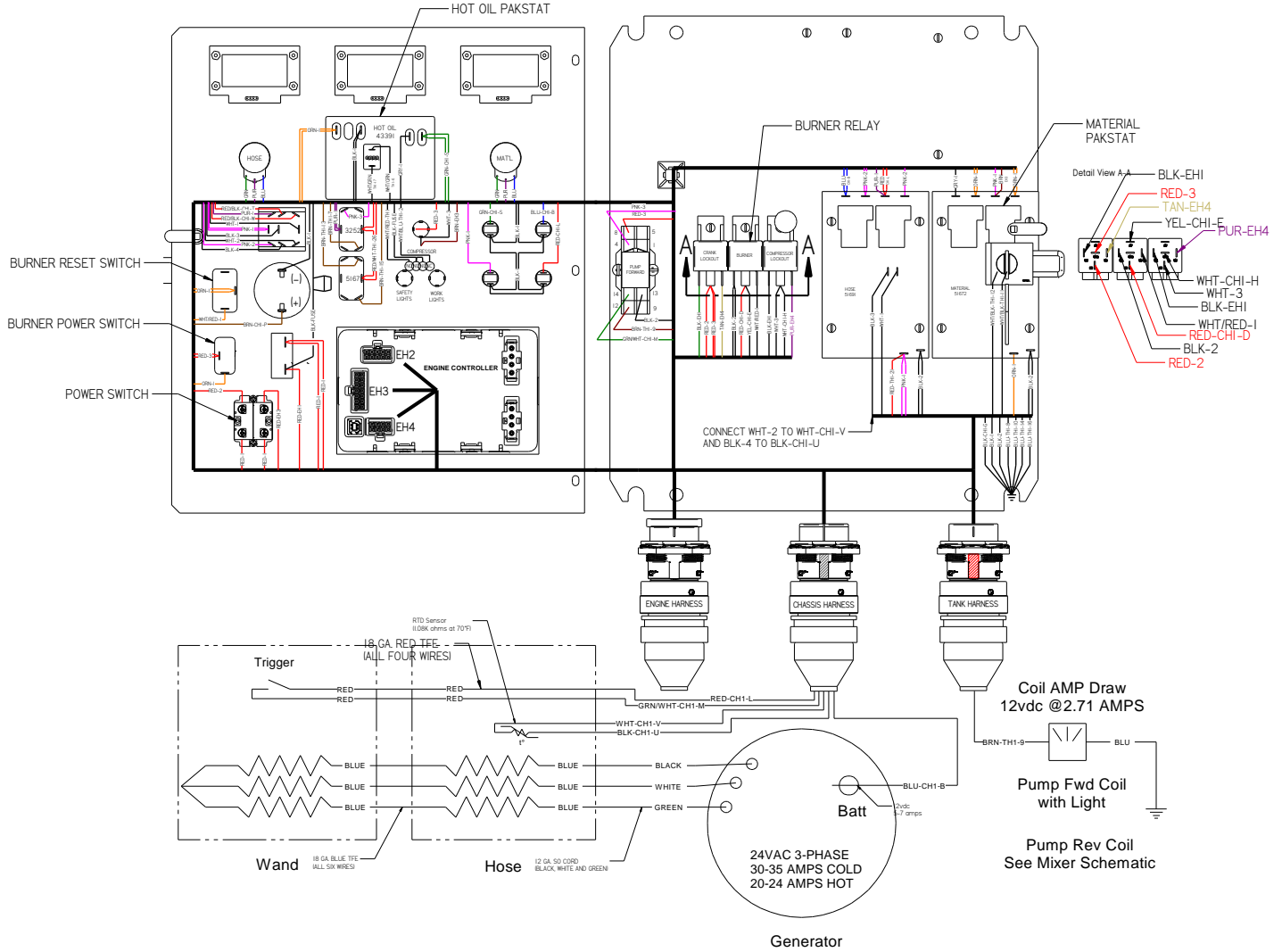

Chapter 8 Troubleshooting

8.4.2 Pump Hydraulic Troubleshooting

Table 8-30 Hydraulic Troubleshooting

Step	Possible Cause	If...
1	Does the coil magnetize when the din plug amber light is “ON”?	<ul style="list-style-type: none"> • Yes, go to Step 2. • No, remove the din plug, then remove the coil by unscrewing the nut on the end of the coil. With the coil removed reattach the din plug and place a metal screwdriver in the center of the coil to see if the coil is magnetic. If it is not, recheck the din plug is plugged into the coil and the amber light is “ON”. If still not magnetic replace the coil.
2	Is the relief pressure set correctly? (Refer to Fig. 8-6 Hydraulic Valve Pressure Setting).	<ul style="list-style-type: none"> • Yes, go to Step 3. • No, first turn “OFF” the Isuzu engine, then remove one of the two hydraulic hoses going to the pump hydraulic motor, cap off the fitting on the motor and use a 3000 PSI gauge with the proper JIC fitting, attach it to the hose. Start the Isuzu engine, turn “ON” the main power in the control box, pull the wand trigger and read the pressure gauge. If the pressure needs to be adjusted use the pressure relief valve marked “RVP”, loosen the jam nut and adjust the pressure with the allen screw at the end of the relief. Turn clockwise to increase pressure and counterclockwise to decrease pressure, then tighten the jam nut to lock pressure. Next turn “OFF” the Isuzu engine, remove the cap, pressure gauge and reattach the hose.
3	Is the hydraulic flow correct from the hydraulic pump? (Refer to Fig. 8-6 Hydraulic Valve Pressure Setting).	<ul style="list-style-type: none"> • Yes, call Crafco, Inc. and speak to a service technician. You should have been able to find the problem. • No, call a local hydraulic shop to see if they can run a hydraulic pump flow test, using the information in Fig. 8-6 Hydraulic Valve Pressure Setting.

Chapter 9 Illustrated Parts List

9.0 About the Illustrated Parts List

The Illustrated Parts List (IPL) is designed to help technical service or maintenance personnel correctly identify orderable replacement parts.

The figure and table titles reference the part number (PN) to which they apply. The PN's for each of the EZ 1500 Series II Diesel Melter machine models are as follows:

EZ1500 Series II Electric Base Diesel Melter PN46400EB

EZ1500 Series II Standard Base Diesel Melter PN46400SB

Illustrations are designed to show general shape and size of a part and the relationship that part has to other parts. Actual size and shape of parts or components may differ or vary from the actual part or component.

9.1 Ordering Crafco Parts

Crafco distributors and Crafco Pavement Preservation Supply Centers are strategically located throughout the United States. Parts can be ordered from your local Crafco distributor or directly from Crafco, Inc. if a distributor is not available in your area.

When ordering parts, give the following information:

- Part Number
- Machine Model
- Serial Number

Write, call, or Fax Crafco, Inc. at the following:

Crafco, Inc. Headquarters

6165 W. Detroit Street

Chandler, AZ 85226

Phone: (602) 276-0406

Toll Free: (800) 528-8242

Fax: (480) 961-0513

Visit our website at www.crafco.com

Chapter 9 Illustrated Parts List

9.2 EZ1500 Series II Melter

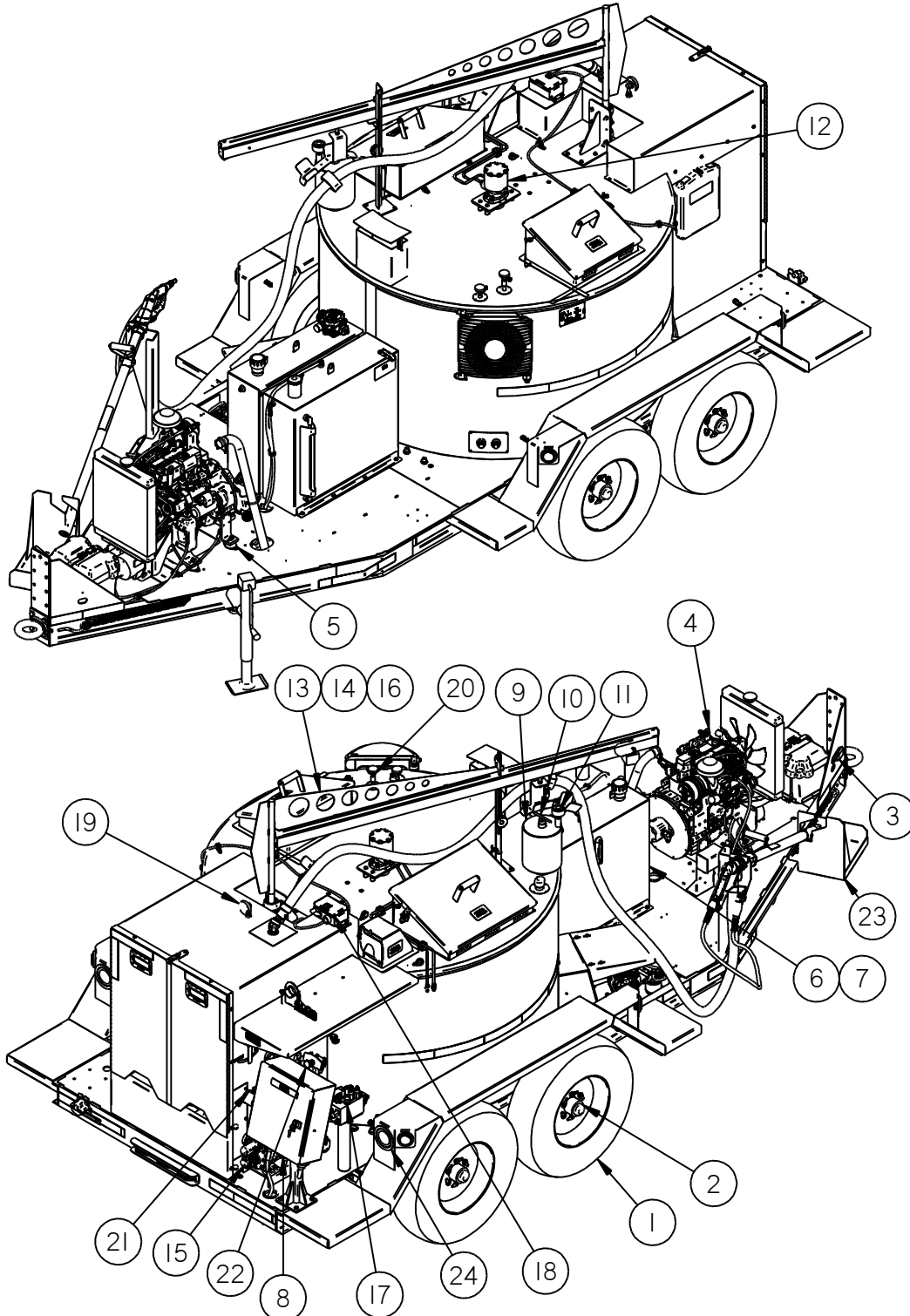

Fig. 9-1 EZ1500 Series II Melter

Chapter 9 Illustrated Parts List

FIG.	ITEM	PART NO.	DESCRIPTION	QTY.
Fig. 9-1	1	90100	TIRE AND WHEEL ASSEMBLY	4
	2	45704	TORSIONAL AXLE ASSEMBLY	2
	3	23117	BREAKAWAY SWITCH	1
	4	47125N	ENGINE ASSEMBLY – 46400EB	1
	4	47128N	ENGINE ASSEMBLY – 46400SB	1
	5	29399	ISOMOUNT	4
	6	46255	HYDRAULIC TANK ASSEMBLY	1
	7	45498	HYDRAULIC FILTER ASSEMBLY	1
	7a	45438	HYDRAULIC FILTER ELEMENT	1
	7b	45440	O-RING, HYDRAULIC FILTER	1
	7c	45497	GASKET, HYDRAULIC FILTER	1
	8	47255N	CONTROL BOX ASSEMBLY – ELECTRIC	1
	8	47260N	CONTROL BOX ASSEMBLY – STANDARD	1
	9	43355	OVERFLOW TANK	1
	10	46450	DIPSTICK	1
	11	26025	AIR BREATHER	1
	12	45706	MOTOR, HYDRAULIC – AGITATOR	1
	13	46010	BOOM – HOSE	1
	14	45579	BASE, BOOM	1
	15	42070	MATERIAL PUMP ASSEMBLY, JACKETED	1
	16	45553	BEARING, BOOM	2
	17	45433	HYDRAULIC CONTROL VALVE ASSEMBLY	1
	18	44027	JUNCTION BOX ASSEMBLY	1
	19	25057	GAUGE, HOSE COMPARTMENT	1
20	43465	SENSOR, RTD	2	
21	56940	SENSOR, RTD – PUMPING TEMPERATURE	1	
22	46060	REGULATOR, FLOW	1	
23	46041	DRIP PAN	1	
24	32363	TAILLIGHT, STOP, TURN, AND TAIL	2	

Chapter 9 Illustrated Parts List

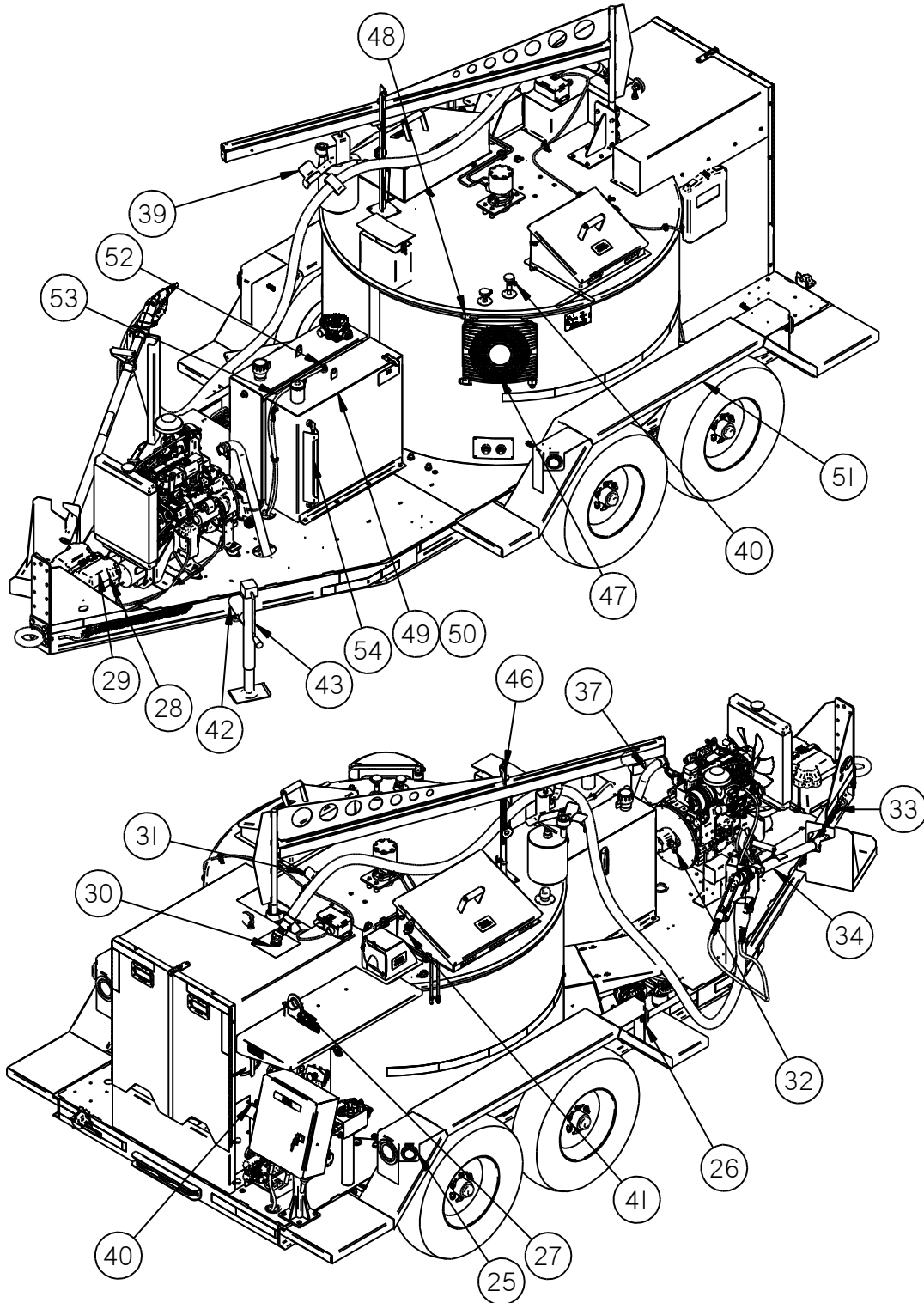

Fig. 9-2 EZ1500 Series II Melter

Chapter 9 Illustrated Parts List

FIG.	ITEM	PART NO.	DESCRIPTION	QTY.
Fig. 9-2	25	24040	SIDE MARKER, RED	2
	26	24041	CLEARANCE MARKER, YELLOW	2
	27	44185	SUPPORT ASSEMBLY, WAND	1
	28	24000	BATTERY	1
	29	24002	BATTERY BOX	1
	30	27048	SWIVEL, STANDARD HOSE (Not Shown)	OPT.
	31	46340	SUPPORT, ELECTRIC HOSE	1
	32	45448	HYDRAULIC PUMP ASSEMBLY – EB/SB	1
	33	20130	SAFETY CHAIN	2
	34	52200	WAND ASSEMBLY – ELECTRIC	OPT.
	35	41629	WAND – STANDARD HOSE (Not Shown)	OPT.
	36	41208	HANDLE W/ VALVE (Not Shown)	OPT.
	37	45372	EXHAUST PIPE – EB/SB/SC63	1
	38	42559	NOZZLE, BURNER (Not Shown)	1
	39	46053	HOSE HANGER	1
	40	51065	CORD GRIP	3
	41	39608	SWITCH, LID	2
	42	23095	BUSHING, JACK ASSEMBLY	1
	43	23082	JACK ASSEMBLY, 7000#	1
	44	52400	ELECTRIC HEATED HOSE ASSEMBLY, 15'	OPT.
	45	27009	HOSE, 20' SEALANT (Not Shown)	OPT.
	46	46263	BOOM LOCK ASSEMBLY	1
	47	45762	HYDRAULIC OIL COOLER	1
	48	45542	TEMPERATURE SWITCH, COOLER	1
	49	47070N	DIESEL FUEL TANK ASSEMBLY	1
	50	43732N	CAP, NON-VENTED DIESEL FUEL	1
	51	46572	FENDER ASSEMBLY	2
	52	43734N	SAFETY VENT	1
	53	29667N	VENT TUBE	1
	54	44191	FUEL SIGHT TUBING	1.75 ft

Chapter 9 Illustrated Parts List

9.3 EZ1500 Series II Melter Options

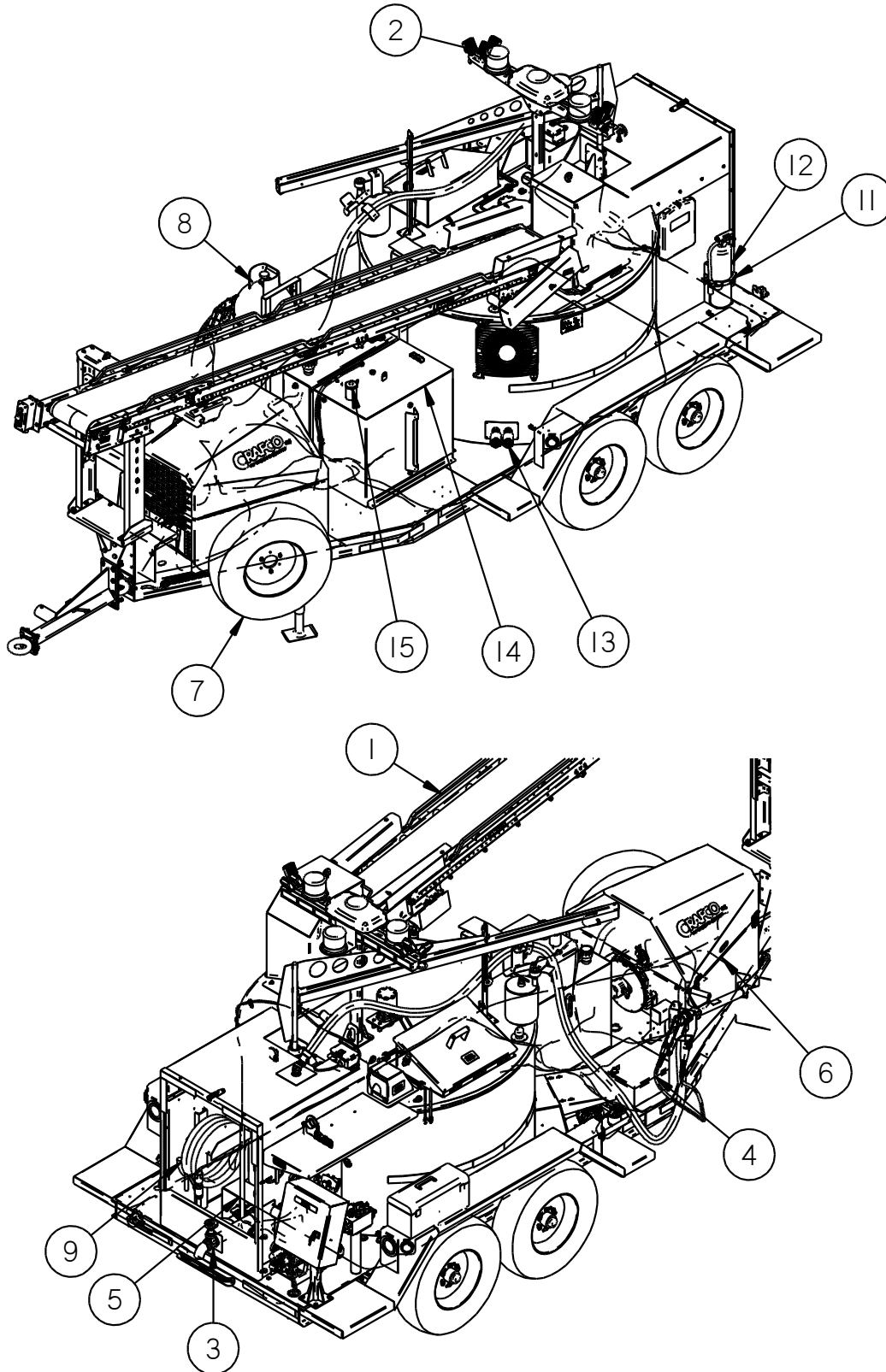

Fig. 9-3 EZ1500 Series II Melter Options

Chapter 9 Illustrated Parts List

FIG.	ITEM	PART NO.	DESCRIPTION	QTY.
Fig. 9-3	1	51399	CONVEYOR ASSEMBLY	1
	2	VARIOUS	SAFETY & WORK LIGHTS, SEE SALES BROCHURE	1
	3	41930	KIT, GRAVITY FEED	1
	4	46260	TOOLBOX	1
	5	41629	HAND WAND ASSEMBLY	1
	5	41208	HANDLE ASSEMBLY W/ VALVE	1
	6	45535	ENGINE COVER ASSEMBLY	1
	7	42743	KIT, SPARE TIRE	1
	8	41259K	KIT, 100# PROPANE TANK	1
	9	27009	20' SEALANT HOSE	1
	10	26119	3/8" SAFETY HOOK (NOT SHOWN)	2
	11	26059	BRACKET, FIRE EXTINGUISHER	1
	12	26058	FIRE EXTINGUISHER W/ COVER	1
	13	24190K	HEATER, FIREROD, 110V	1
	13	24194K	HEATER, FIREROD, 220V	1
	14	47090N	FUEL TANK ASSY, 60 GAL. DOT	1
15	43732N	CAP, NON-VENTED DIESEL FUEL	1	
	NS	29599	SEALANT HOSE EXTENSION (NOT SHOWN)	1

Chapter 9 Illustrated Parts List

9.4 Optional Engine Cover

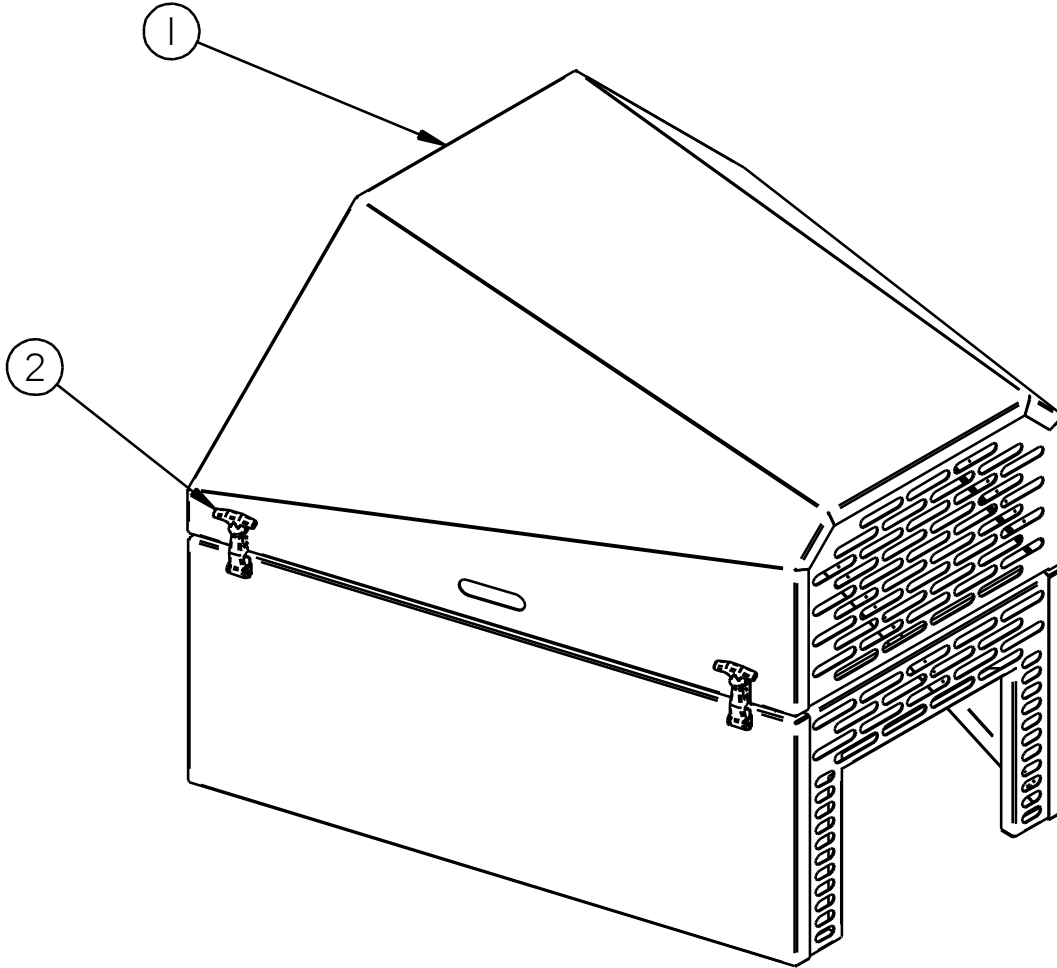

Fig. 9-4 Optional Engine Cover

FIG.	ITEM	PART NO.	DESCRIPTION	QTY.
Fig. 9-4	1	45535	ENGINE COVER	1
	2	45600	LATCH, RUBBER T-HANDLE REPLACEMENT	1
	N/S	46748	GAS SPRING – NOT SHOWN	1
	N/S	46374	INSULATION KIT, ENGINE COVER – NOT SHOWN	1

Chapter 9 Illustrated Parts List

9.5 Tank Assembly

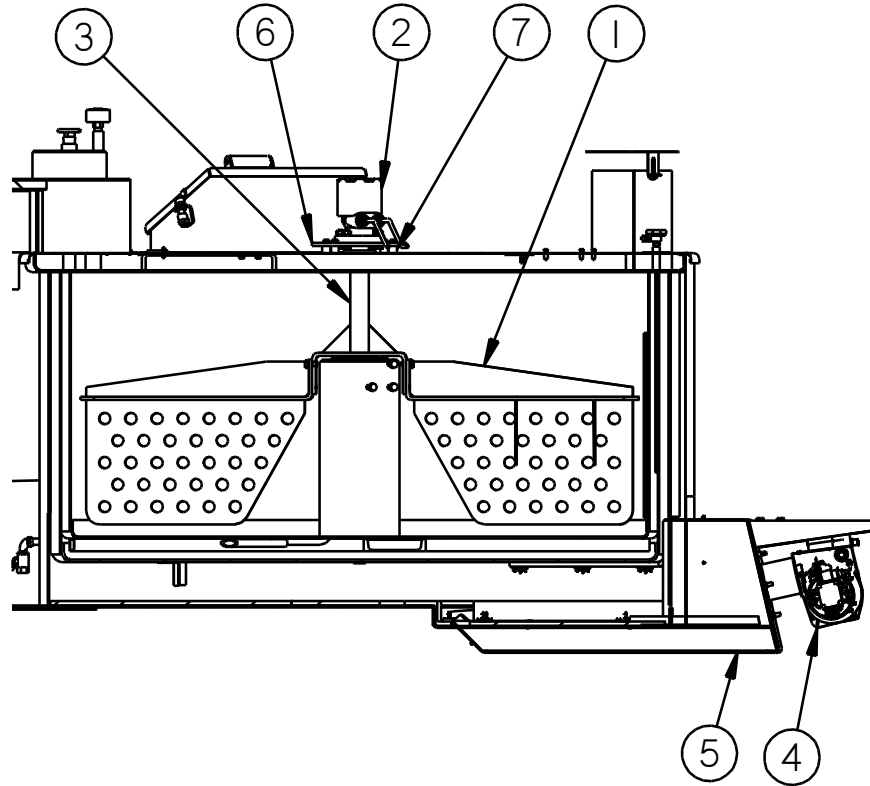

Fig. 9-5 Tank Detail

FIG.	ITEM	PART NO.	DESCRIPTION	QTY.
Fig. 9-5	1	46531	PADDLE, AGITATOR	2
	2	45706	MOTOR, HYDRAULIC – AGITATOR	1
	3	46050	SHAFT ASSEMBLY – AGITATOR	1
	4	46380	BURNER, 14 VOLT DIESEL	1
	5	46495	BURNER BOX ASSEMBLY, EXTENDED	1
	5a	46489	BURNER BOX INSULATION KIT	1
	6	42573	MOUNTING PLATE – MOTOR	1
	7	40030	SPACER. MOTOR	4

Chapter 9 Illustrated Parts List

9.6 Plumbing

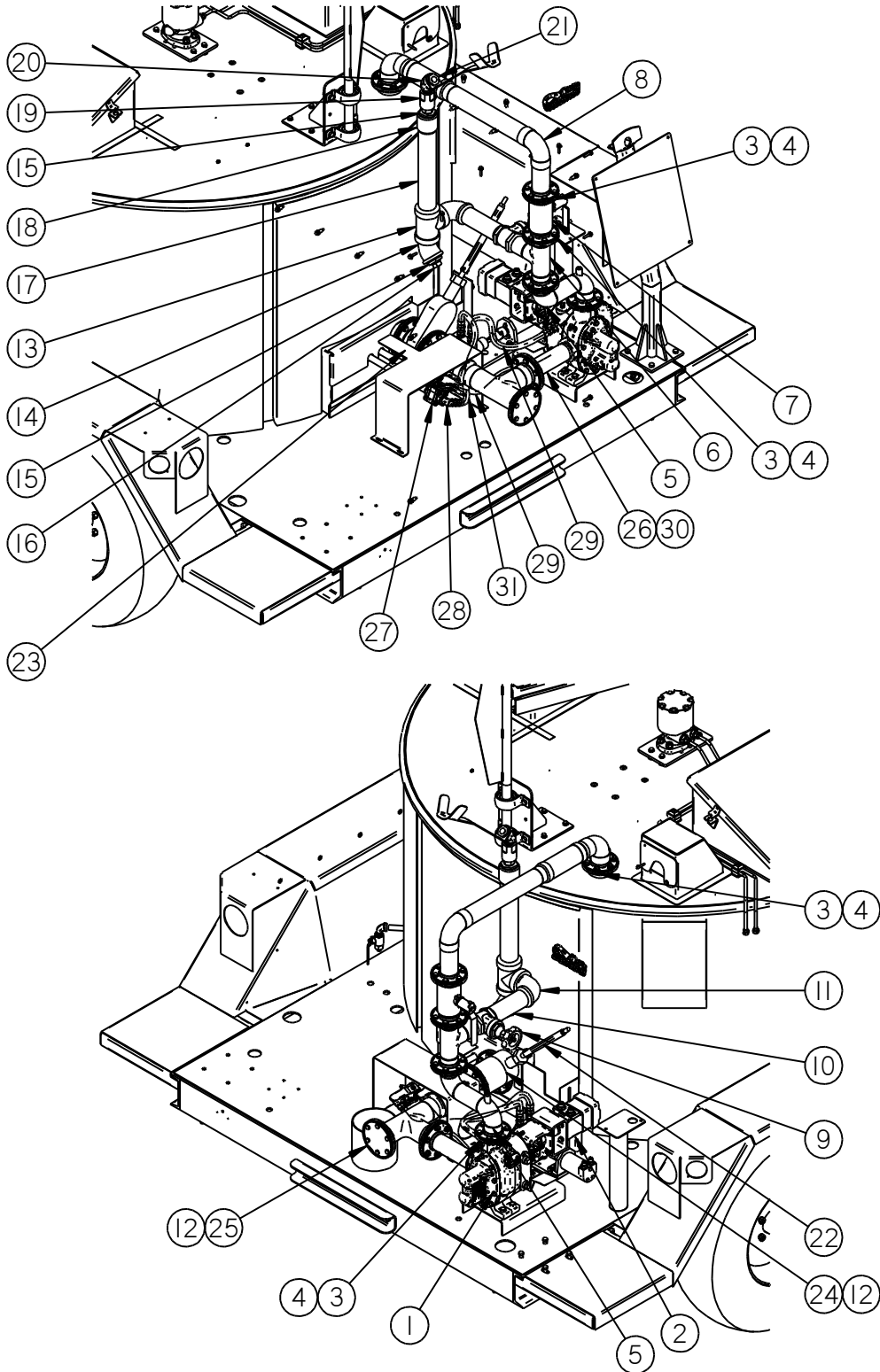

Fig. 9-6 Plumbing

Chapter 9 Illustrated Parts List

FIG.	ITEM	PART NO.	DESCRIPTION	QTY.
Fig. 9-6	1	42070	MATERIAL PUMP ASSEMBLY, JACKETED	1
	2	22027	HYDRAULIC MOTOR	1
	3	22030	NIPPLE ASSEMBLY, FLANGED	4
	4	29050	GASKET, 2" CIRCULAR FLANGED	5
	5	46547	ELBOW, DOUBLE	1
	6	46644	FLANGED TEE	1
	7	41246	VALVE, 2" BALL	1
	8	46642	PIPING ASSEMBLY, UPPER	1
	9	29270	VALVE, 2" GATE	1
	10	28110	NIPPLE, 2" NPT X 8" LG.	1
	11	28243	ELBOW, 2" STREET	1
	12	29060	GASKET, 3" CIRCULAR FLANGED	2
	13	28258	TEE, 2" PIPE	1
	14	28242	ELBOW, 2" 45° STREET	1
	15	28358	BUSHING, 2" X 1" HEX HEAD REDUCER	2
	16	28285	PLUG, 1" SQ. HEAD PIPE	1
	17	28190	NIPPLE, 2" NPT X 14 1/2" LG.	1
	18	28183	COUPLING, 2" PIPE	1
	19	27048	SWIVEL, 1" PIPE	1
	20	28225	ELBOW, 1" STREET	1
	21	28351	BUSHING, 1" X 3/4" HEX HEAD REDUCER	1
	22	46509	EXTENSION, VALVE HANDLE	1
	23	46570	DRAINPIPE EXTENSION	1
	24	29292	VALVE, 3" FLANGED GATE	1
	25	46645	PIPE ASSEMBLY, MATERIAL SUCTION	1
	26	46549	MATERIAL PIPE ASSEMBLY, PUMP SUCTION	1
	27	41499	VALVE, HOT OIL	2
	28	29845	ADAPTER	2
	29	41404	FLEX HOSE ASSEMBLY, HOT OIL	2
	30	41043	GASKET, 2.5" FLANGED	1
	31	47658N	FLEX HOSE ASSEMBLY, HOT OIL	1

Chapter 9 Illustrated Parts List

9.7 Control Box Assembly 47202 – 46400EB - Electric Hose

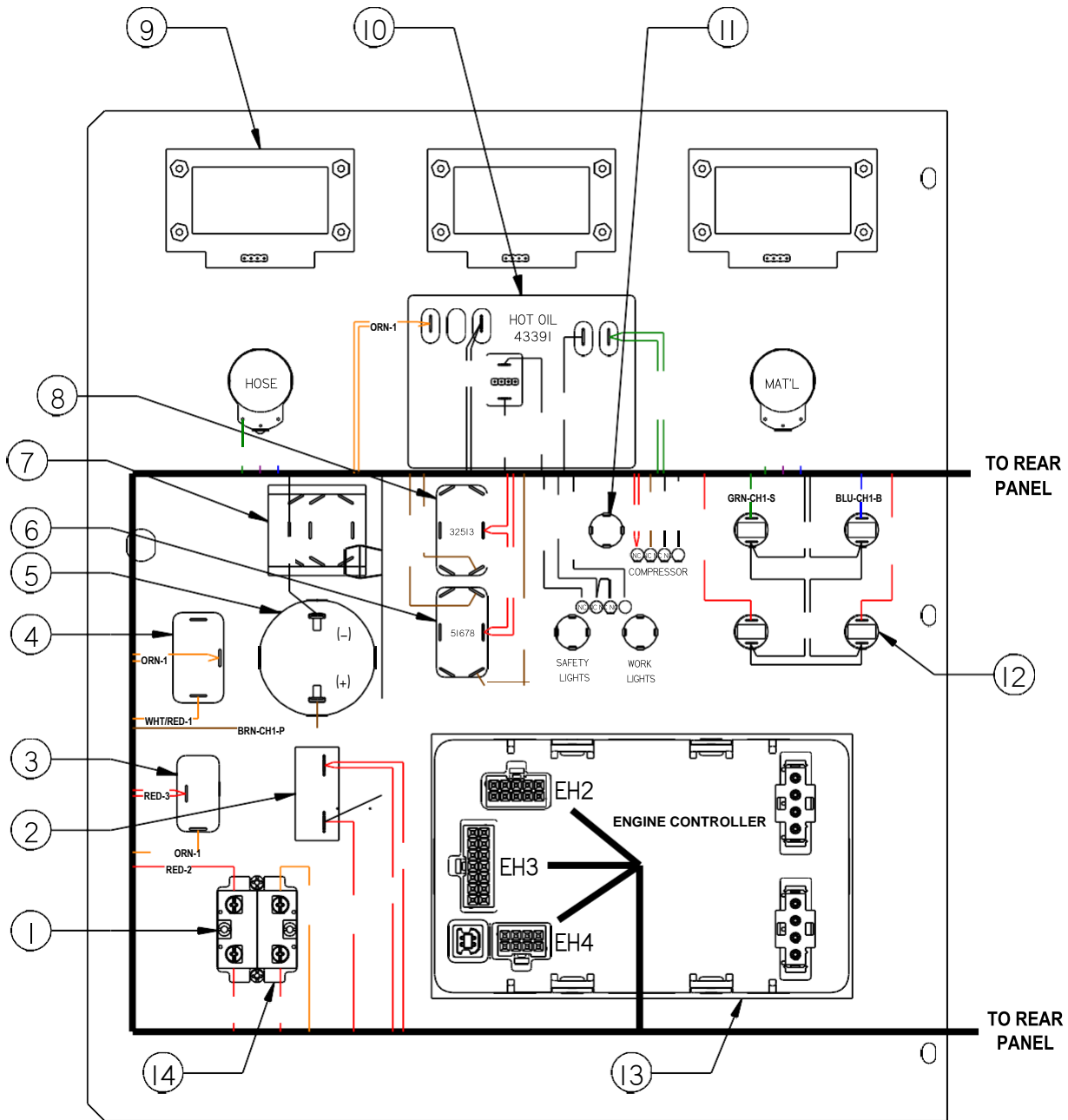

CIRCUIT NAMING CONVENTION:

CIRCUITS ARE NAMED BY COLOR, THEN CONNECTOR OF ORIGIN (IF APPLICABLE), THEN CAVITY NUMBER. IF THERE IS NO CONNECTOR OF ORIGIN, THEN THE CIRCUIT IS ENTIRELY WITHIN THE BOX AND IS SIMPLY

NUMBERED CONNECTOR ABBREVIATIONS:

"EH-" = ENGINE HARNESS PIGTAIL, CONNECTOR 1, 2, 3 ETC. "CH1" = CHASSIS HARNESS PIGTAIL, ONLY 1 CONNECTOR "TH1" = TANK HARNESS PIGTAIL, ONLY 1 CONNECTOR

Fig. 9-7 Control Box Assembly 47255N– 46400EB

Chapter 9 Illustrated Parts List

FIG.	ITEM	PART NO.	DESCRIPTION	QTY.
Fig. 9-7	1	51852	CONTACT BLOCK, N.O.	2
	2	51665	CIRCUIT BREAKER, 15 AMP	1
	3	50719	TOGGLE SWITCH, SPST ON-OFF	1
	4	52338	TOGGLE SWITCH, SPDT ON-(ON)	1
	5	46494	ALARM, PIEZO	1
	6	51678	TOGGLE SWITCH, SPDT, ON-OFF-(ON)	1
	7	51811	TOGGLE SWITCH, 3PDT ON-ON	1
	8	32513	TOGGLE SWITCH, DPDT ON-(ON)	1
	9	50251	DIGITAL READOUT	3
	10	43391	TEMPERATURE CONTROLLER, 150F-550F	1
	11	24269	PLUG, 1/2"	3
	12	51651	LIGHT, PILOT 12VDC	4
	13	38090N	CONTROLLER – DYNAGEN, GENERIC SW	1
	14	46239	SWITCH, ON/OFF SELECTOR, W/KEY	1

Chapter 9 Illustrated Parts List

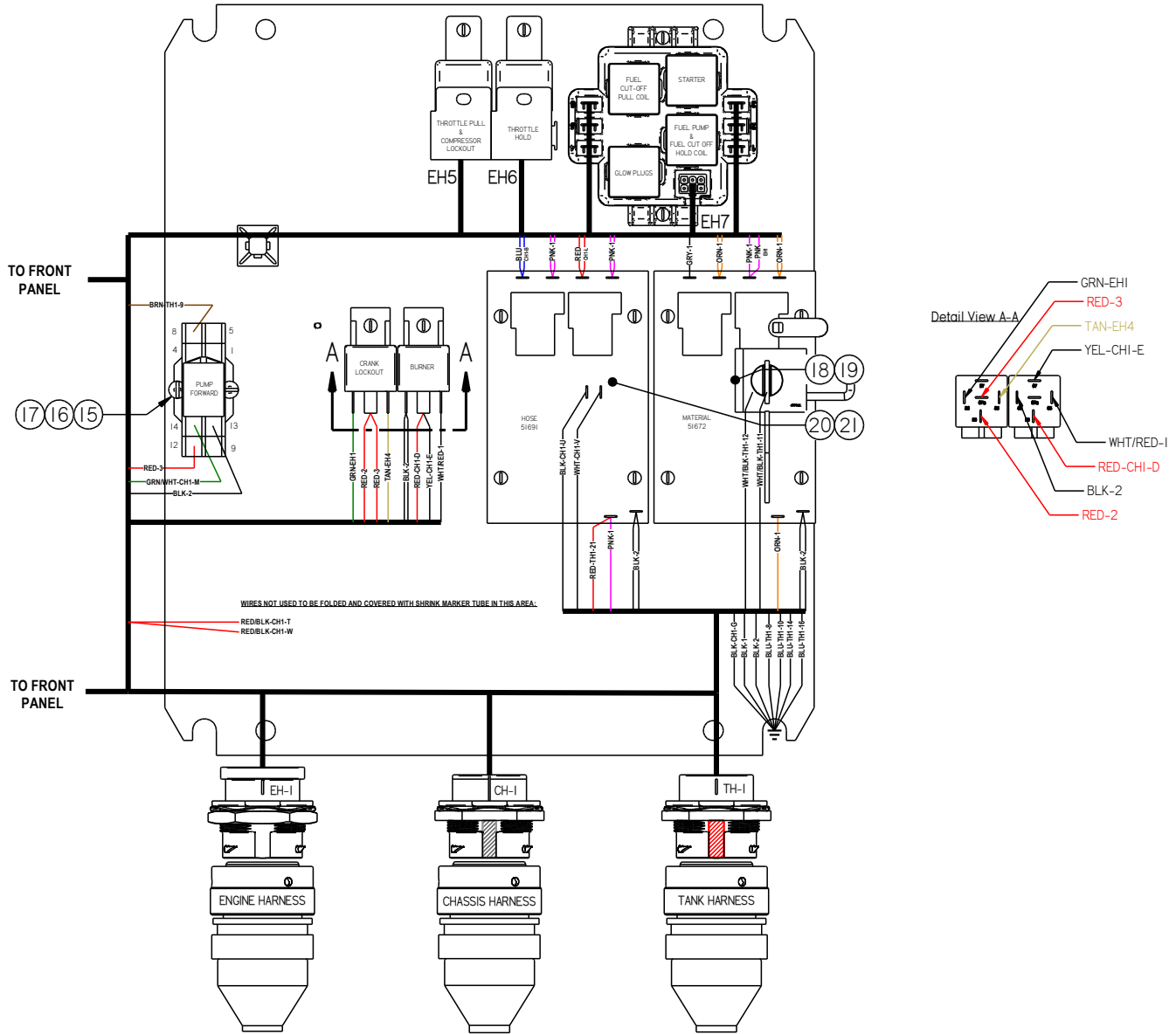

Fig. 9-8 Control Box Assembly 47255N-46400EB

Chapter 9 Illustrated Parts List

FIG.	ITEM	PART NO.	DESCRIPTION	QTY.
Fig. 9-8	14	51661	RELAY, DPDT 12 VDC	1
	15	51662	BASE, RELAY	1
	17	51663	SPRING, HOLD DOWN	1
	18	51670	SPACER, ¼ O.D. X 3/8 LG.	4
	19	51672	PAKSTAT W/INTERLOCK 400°/275°F	1
	20	51670	SPACER, ¼ O.D. X 3/8 LG.	4
	21	51691	PAKSTAT W/INTERLOCK 400°/325°F	1

Chapter 9 Illustrated Parts List

9.8 Control Box Assembly 47260N – 46400SB - Standard Hose

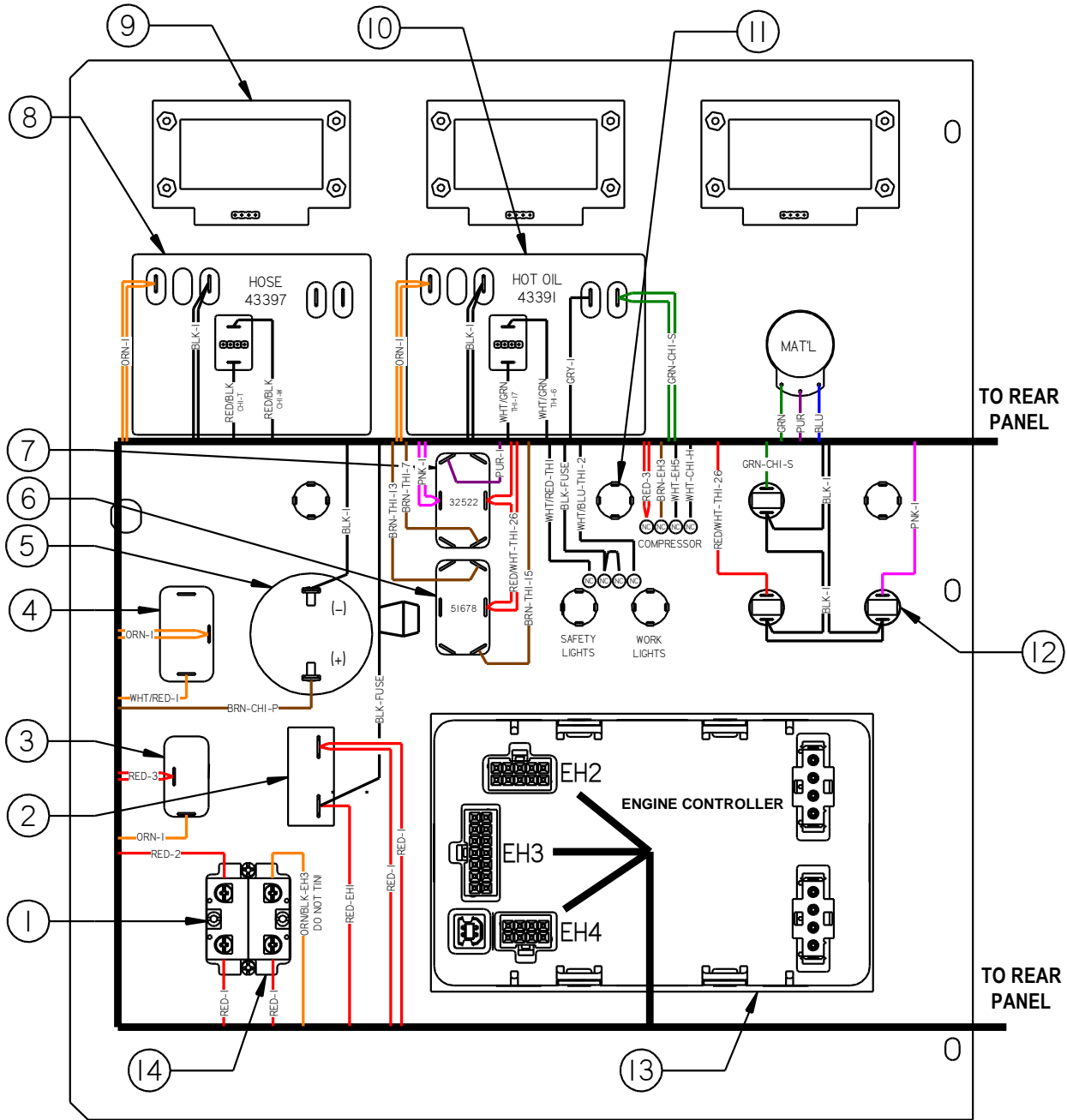

CIRCUIT NAMING CONVENTION:

CIRCUITS ARE NAMED BY COLOR, THEN CONNECTOR OF ORIGIN (IF APPLICABLE), THEN CAVITY NUMBER.
IF THERE IS NO CONNECTOR OF ORIGIN, THEN THE CIRCUIT IS ENTIRELY WITHIN THE BOX AND IS SIMPLY NUMBERED

CONNECTOR ABBREVIATIONS:

- "EH-" = ENGINE HARNESS PIGTAIL, CONNECTOR 1, 2, 3 ETC.
- "CHI" = CHASSIS HARNESS PIGTAIL, ONLY 1 CONNECTOR
- "THI" = TANK HARNESS PIGTAIL, ONLY 1 CONNECTOR

Fig. 9-9 Control Box Assembly 47260N– 46400SB

Chapter 9 Illustrated Parts List

FIG.	ITEM	PART NO.	DESCRIPTION	QTY.
Fig. 9-9	1	51852	CONTACT BLOCK N.O.	2
	2	51665	CIRCUIT BREAKER	1
	3	50716	TOGGLE SWITCH, SPDT ON-OFF	1
	4	52338	TOGGLE SWITCH, SPDT ON-(ON), WASHDOWN	1
	5	46494	ALARM, PIEZO	1
	6	51678	TOGGLE SWITCH, SPDT ON-OFF-(ON)	1
	7	32522	TOGGLE SWITCH, DPDT ON-OFF-ON, WASHDOWN	1
	8	43397	TEMPERATURE CONTROLLER, 150°F-550°F	1
	9	50251	DIGITAL READOUT W/ BEZEL	3
	10	43391	TEMPERATURE CONTROLLER, 150°F-550°F	1
	11	24269	PLUG, ½"	5
	12	51651	LIGHT, PILOT 12 VDC	3
	13	38090N	CONTROLLER-DYNAGEN, GENERIC SW	1
	14	46239	SWITCH, ON-OFF W/KEY (FRONT PANEL)	1

Chapter 9 Illustrated Parts List

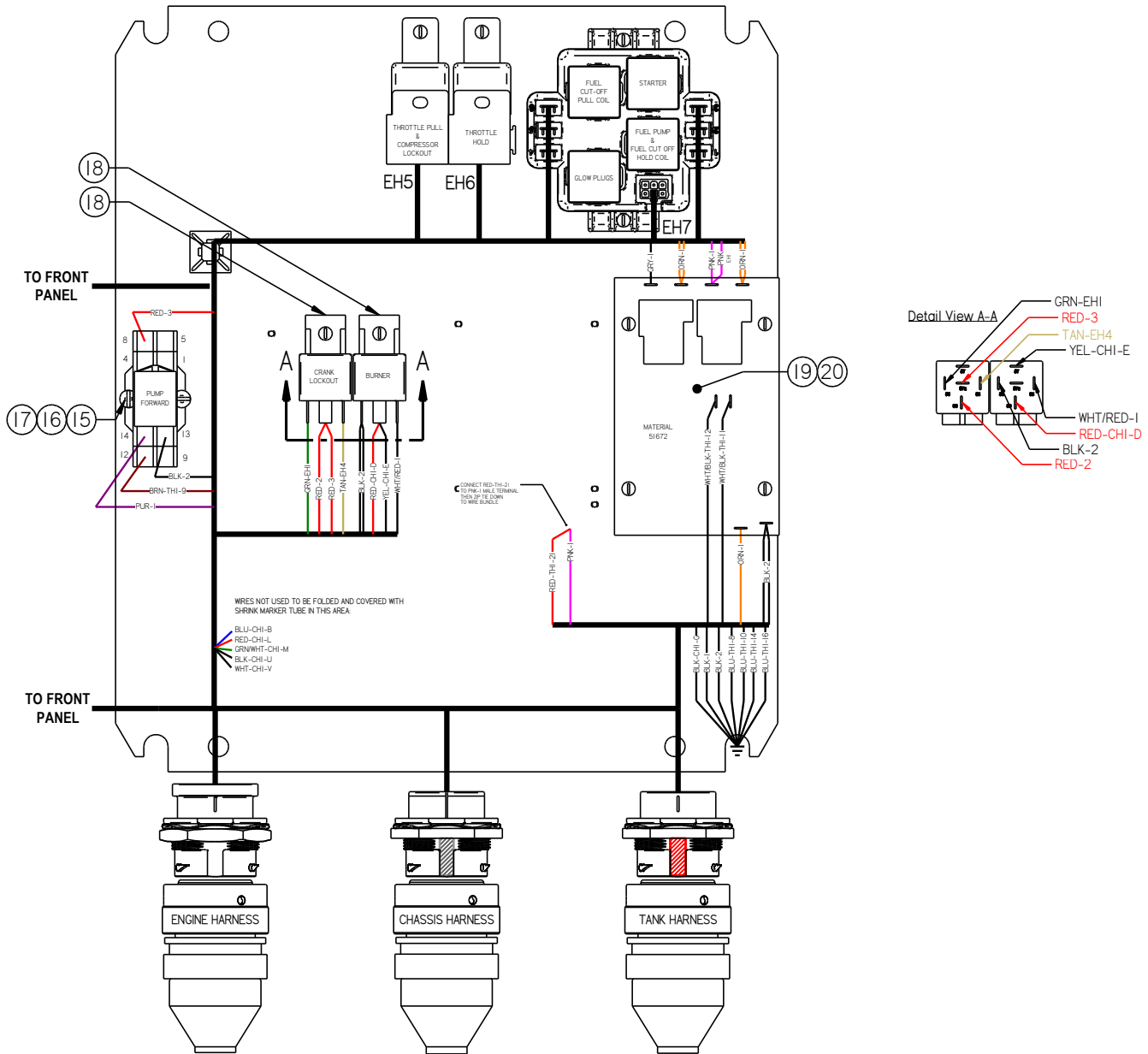

Fig. 9-10 Control Box Assembly 47260N- 46400SB

Chapter 9 Illustrated Parts List

FIG.	ITEM	PART NO.	DESCRIPTION	QTY.
Fig. 9-10	15	51661	RELAY, DPDT 12 VDC	1
	16	51662	BASE, RELAY	1
	17	51663	SPRING, HOLD DOWN	1
	18	51673	RELAY	2
	19	51672	PAKSTAT W/INTERLOCK 400°/275°F	1
	20	51670	SPACER, ¼ O.D. X 3/8 LG	4

Chapter 9 Illustrated Parts List

9.9 Engine Assembly

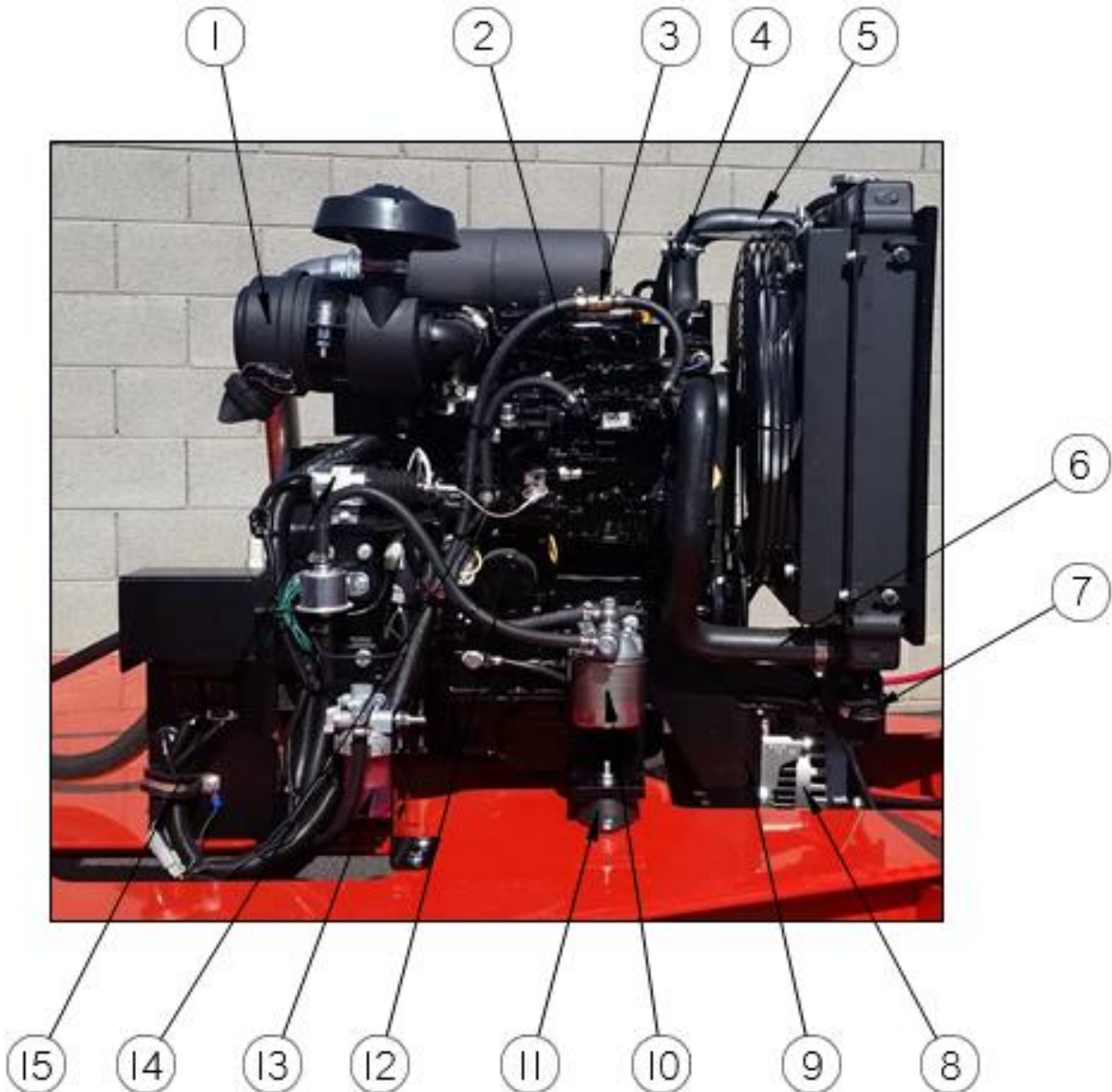

Fig. 9-11 Engine Assembly – 46400EB, 46400SB

Chapter 9 Illustrated Parts List

FIG.	ITEM	PART NO.	DESCRIPTION	QTY.
Fig. 9-11	1	45391	AIR FILTER ELEMENT	1
	2	47125N	ENGINE, 23 HP 3CH1 (46400EB)	1
	2	47128N	ENGINE, 23 HP 3CH1 (46400SB)	1
	3	47149N	VALVE – CHECK INLINE 5/16 BARB	1
	4	47138N	UPPER RADIATOR ISO MOUNT	1
	5	45444U	UPPER RADIATOR HOSE	1
	6	45444L	LOWER RADIATOR HOSE	1
	7	41872	LOWER RADIATOR ISO MOUNT	2
	8	43612	GENERATOR. 24VAC	1
	9	45748	DRIVE BELT, GENERATOR	1
	10	41867	FUEL FILTER	1
	11	29399	ISOMOUNT	2
	12	45389	OIL FILTER	1
	13	47150	WATER SEPARATOR	1
	14	N/A	THROTTLE CABLE ASSEMBLY	1
	15	N/A	THROTTLE SOLENOID	1
	16	45402	HYDRAULIC PUMP (NOT SHOWN)	1
	17	45443N	RADIATOR KIT (RADIATOR, SHROUD, FINGER GUARD, CAP, NOT SHOWN)	1
18	47155N	RADIATOR OVERFLOW BOTTLE KIT (NOT SHOWN)	1	

Chapter 9 Illustrated Parts List

9.10 Hydraulic Control Valve Assembly

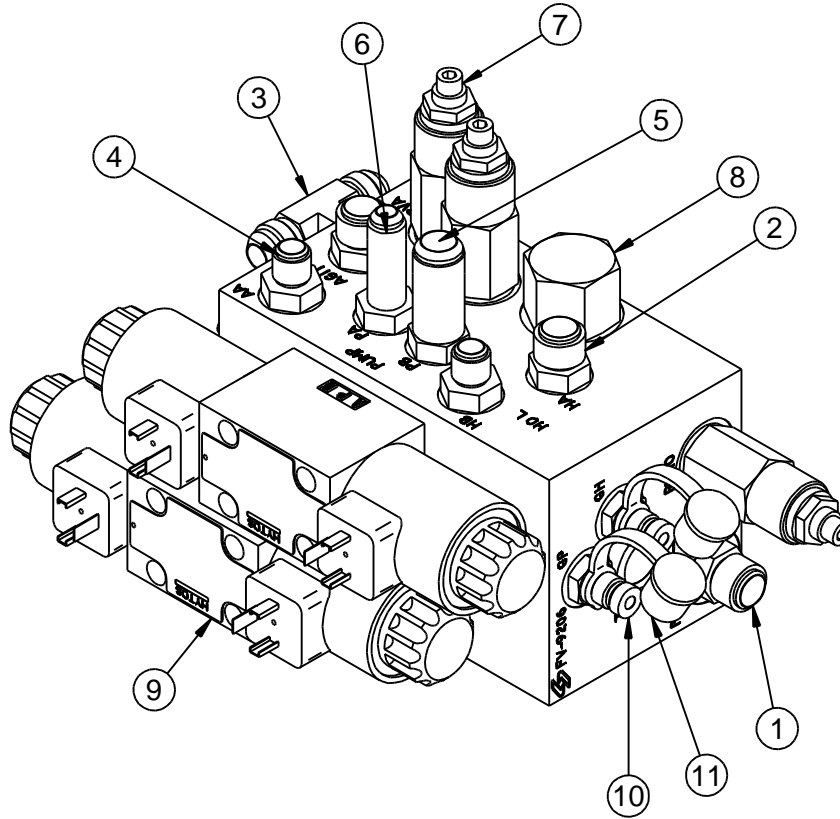

Fig. 9-12 Hydraulic Control Valve

FIG.	ITEM	PART NO.	DESCRIPTION	QTY.
Fig. 9-12	1	29896	3/4-16 ORING ADAPTER	1
	2	29919	9/16-18 ORING X 1/2 JIC ADAPTER	3
	3	29976	3/4-16 ORING BRANCH TEE	1
	4	40311	9/16-18 ORING ADAPTER	2
	5	40320	9/16-18 ORING X 1/2 JIC ADAPTER	2
	6	40308	9/16-18 ORING ADAPTER – LONG	1
	7	45417	RELIEF VALVE	3
	8	45416	FLOW DIVIDER	2
	9	45418	VALVE, DIRECTIONAL	2
	10	45414	FITTING, TEST POINT	3
	11	45413	CAP, DUST – TEST POINT	3

Chapter 9 Illustrated Parts List

9.11 Hydraulic Compressor Valve Assembly

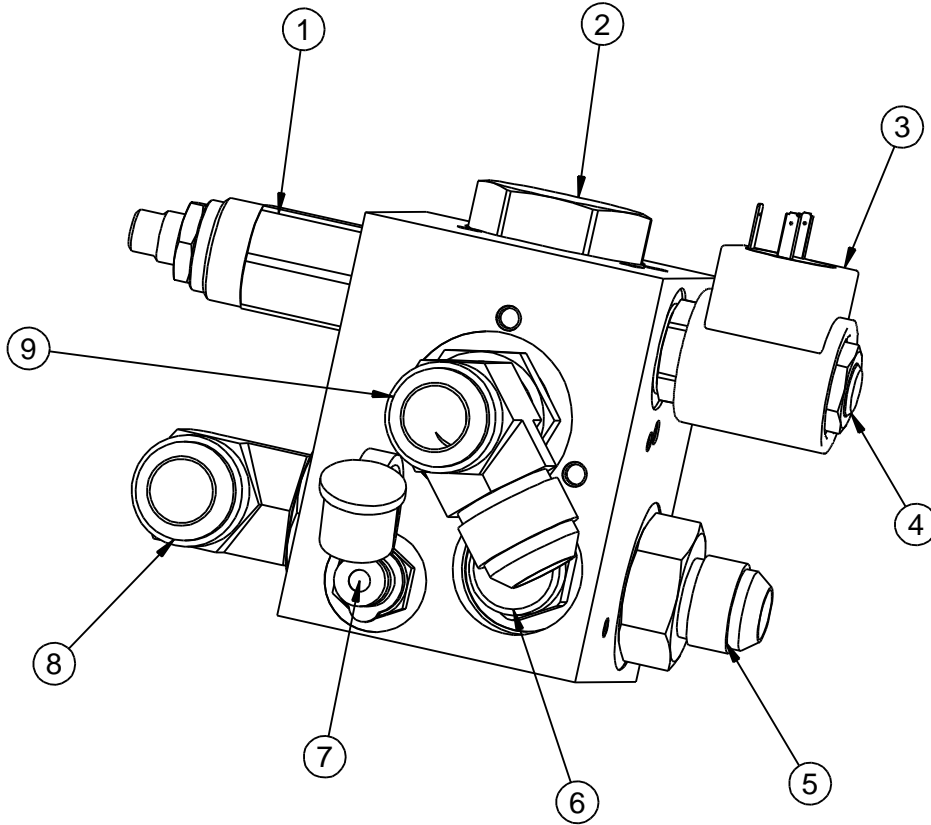

Fig. 9-13 Compressor Valve

FIG.	ITEM	PART NO.	DESCRIPTION	QTY.
Fig. 9-13	1	45417	VALVE, RELIEF	1
	2	45429	VALVE, LOGIC RELIEF	1
	3	45426	COIL, SOLENOID VALVE	1
	4	45424	VALVE, SOLENOID	1
	5	-	FITTING, #12 ORB X #10 JIC STRAIGHT	2
	6	45436	FLOW CONTROL, PRESSURE COMP.	1
	7	45414	FITTING, TEST POINT	1
	8	45413	CAP, DUST	1
	9	-	TEE, #12 ORB X #12 JIC RUN	1

Chapter 9 Illustrated Parts List

9.12 Diesel Burner Assembly

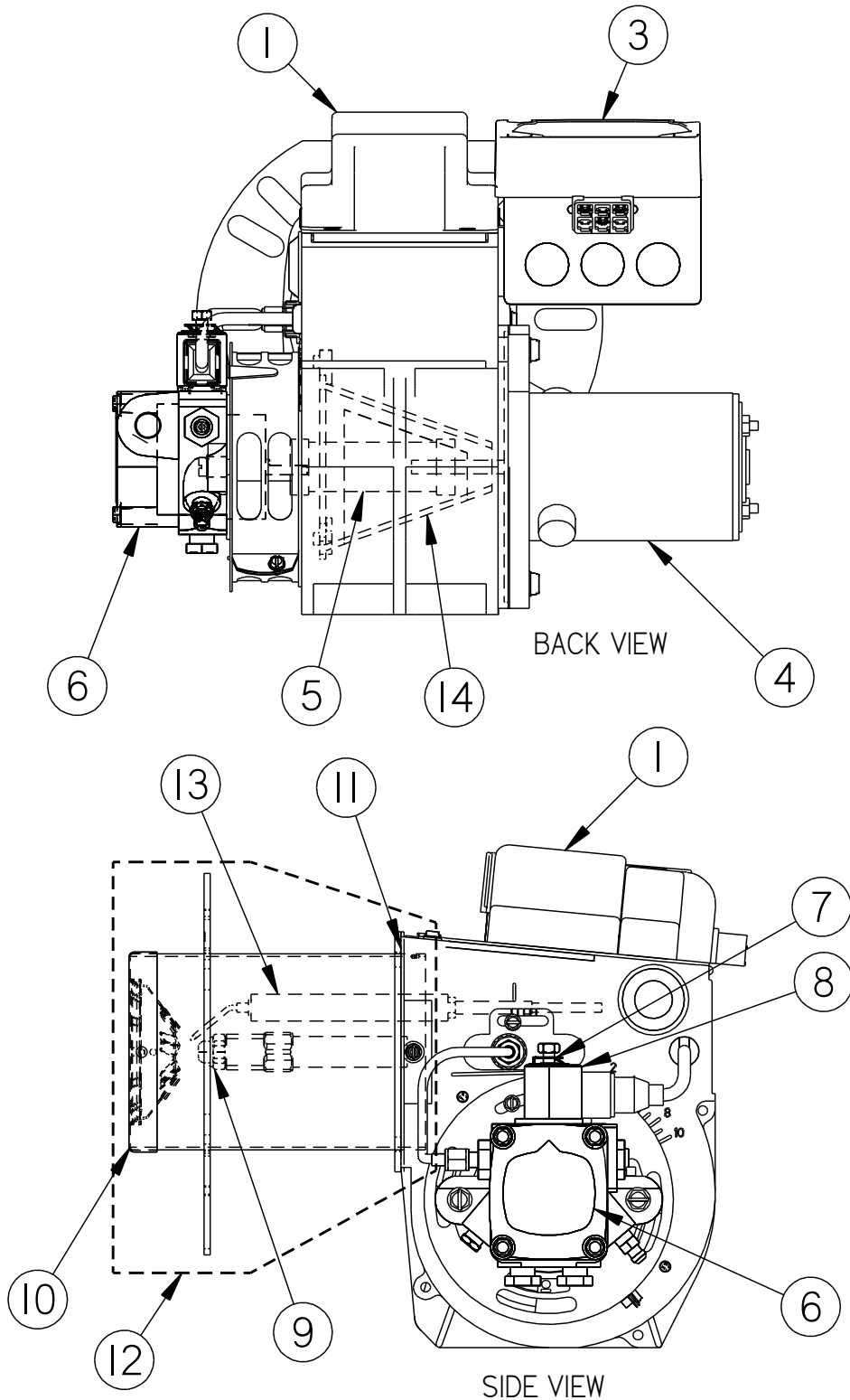

Fig. 9-14 Diesel Burner Assembly

Chapter 9 Illustrated Parts List

FIG.	ITEM	PART NO.	DESCRIPTION	QTY.
Fig. 9-14	1	41949	IGNITION TRANSFORMER	1
	2	41870	CAD EYE (NOT SHOWN)	1
	3	42335	DC CONTROLLER	1
	4	41890	BLOWER MOTOR	1
	5	41970	COUPLING, FUEL PUMP	1
	6	41892	PUMP, FUEL	1
	7	41932	VALVE STEM, FUEL SOLENOID	1
	8	41933	COIL, FUEL SOLENOID	1
	9	42559	NOZZLE	1
	10	41953N	STD HEAD, F22, BURNER	1
	11	41964N	GASKET, AIR TUBE TO HOUSING	1
	12	46381N	AIR TUBE W/ HEAD & ELECTRODE MOUNT	1
	13	41993	ELECTRODE ASSY (COMES WITH 2)	1
	14	41966N	AIR GUIDE, BURNER	1

Chapter 9 Illustrated Parts List

This page left blank intentionally

Chapter 9 Illustrated Parts List

9.13 Material Pump Assembly

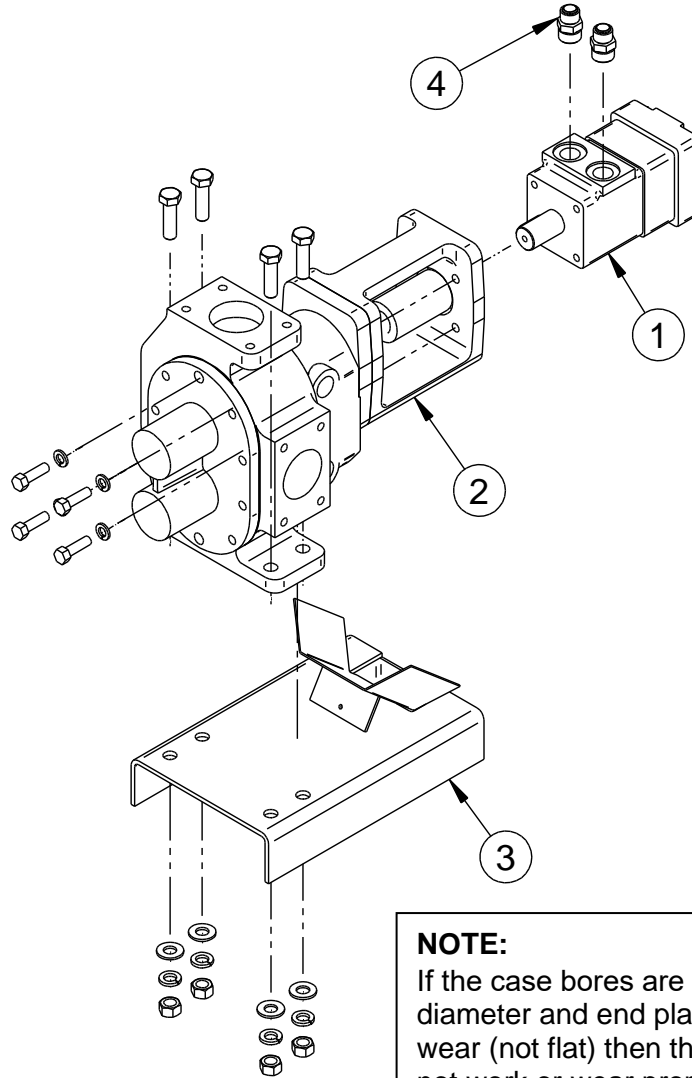

Fig. 9-15 Material Pump Assembly

FIG.	ITEM	PART NO.	DESCRIPTION	QTY.
Fig. 9-15	1	22027	MOTOR, HYDRAULIC	1
	2	42070	MATERIAL PUMP ASSEMBLY, JACKETED	1
	2a	29990S	PACKING RING (SET OF 7)	1
	3	43129	MOUNTING PLATE ASSEMBLY	1
	4	29913	FITTING, #10 ORB X #8 JIC STRAIGHT	2
	NA	42073N	PUMP REBUILD KIT (SEE NOTE)	-

Chapter 9 Illustrated Parts List

9.14 Hot Oil Pump and Motor Assembly

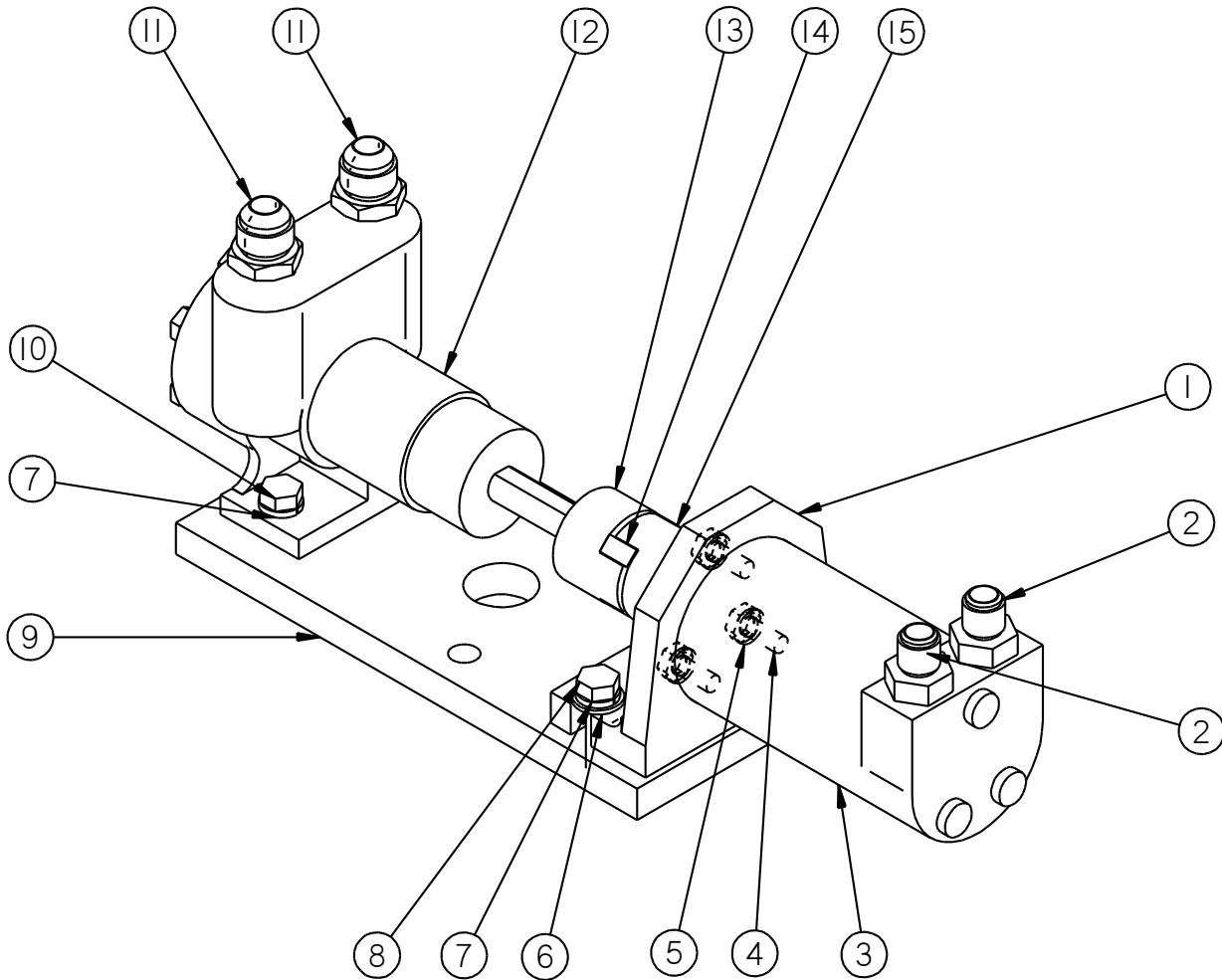

Fig. 9-16 Hot Oil Pump and Motor Assembly

Chapter 9 Illustrated Parts List

FIG.	ITEM	PART NUMBER	QTY	DESCRIPTION
Fig. 9-16	1	22303	1	HYD. MOTOR MNTG BRACKET
	2	40311	2	STRAIGHT THREAD ADAPTER
	3	22302	1	HYDRAULIC MOTOR
	4	28850	3	1/4-28 X 5/8" HEX SCREW
	5	28645	3	1/4" SPLIT WASHER
	6	28671	2	5/16" SAE FLAT WASHER
	7	28646	4	5/16" LOCK WASHER
	8	28717	2	5/16-18 X 1 1/4" BOLT
	9	41689	1	H.O. MOUNTING PLATE
	10	28715	2	5/16-18 X 3/4" BOLT
	11	29844	2	ADAPTER, JIC MP 8MJ-8MP
	12	41280	1	HOT OIL CIRCULATING PUMP
	13	41180	1	COUPLING HALF, 1/2" BORE
	14	41182	1	SPIDER FOR COUPLING
	15	41695	1	COUPLING HALF, 5/8" BORE
	NS	45622	1	OIL PUMP REBUILD KIT, INCLUDES BELOW
		-	6	SCREWS
		-	1	IDLER PIN
		-	1	HEAD
		-	1	IDLER
		-	3	PACKING GLANDS
	NS	45621	1	OIL PUMP SEAL KIT, INCLUDES BELOW
		-	1	NUT
		-	1	OTR GLAND
		-	3	PACKING GLANDS
		-	1	INNER GLAND
		-	1	SPRING
		-	2	HEAD GASKETS
	NS	45620	1	3 PACKING GLAND RINGS, OIL PUMP

Chapter 9 Illustrated Parts List

9.15 Wand Assembly

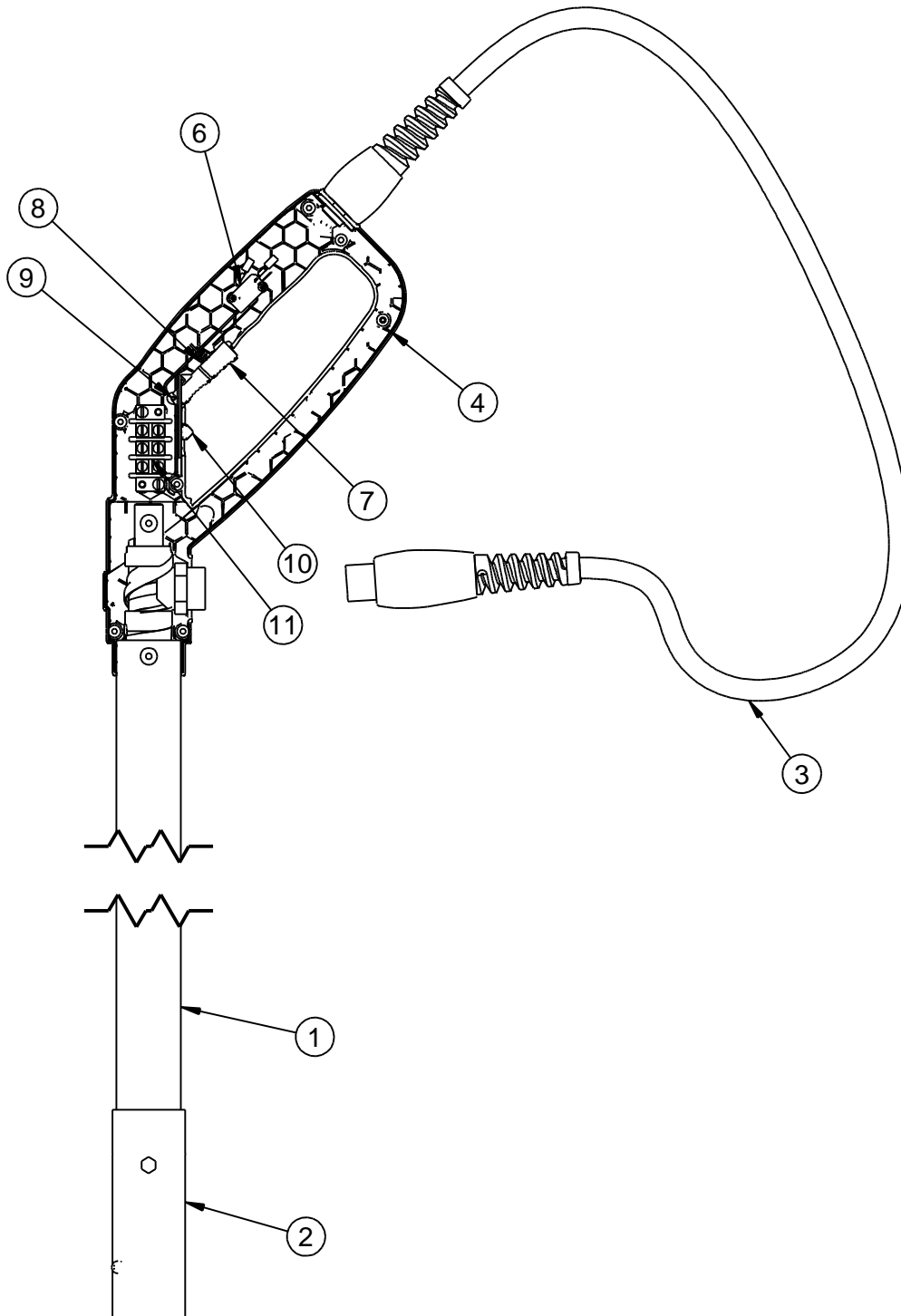

Fig. 9-17 Wand Assembly

Chapter 9 Illustrated Parts List

FIG.	ITEM	PART NO.	DESCRIPTION	QTY.
Fig. 9-17	1	52204	COVER, WAND	1
	2	50278	TIP GUARD, LONG CLAMP ON	1
	3	52206	CORD ASSEMBLY	1
	4	52201RN	HANDLE, WAND – RIGHT (W/INSERTS) GEN 2	1
	5	52201LN	HANDLE, WAND – LEFT (NOT SHOWN) GEN 2	1
	6	52208	SWITCH, WAND	1
	7	52202N	ACTUATOR TRIGGER, GEN 2	1
	8	52207	SPRING, ACTUATOR	1
	9	52209	PIN, ACTUATOR	1
	10	52203N	LOCK, TRIGGER, GEN 2	1
	11	51656	TERMINAL STRIP	1

9.16 Material Flow Control Assembly

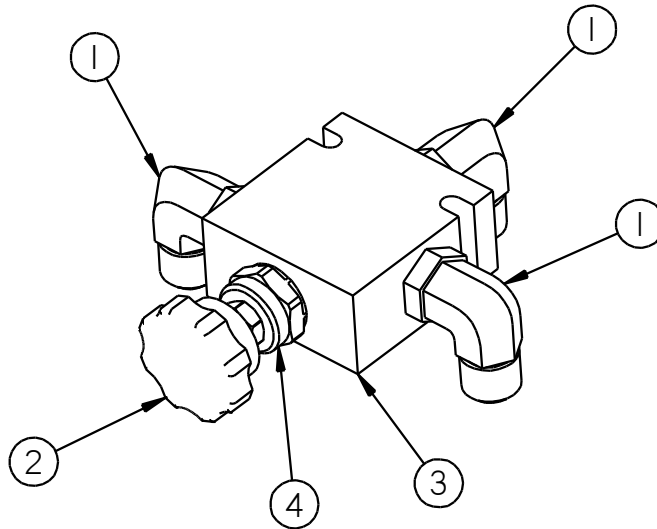

Fig. 9-18 Material Flow Control Assembly

FIG.	ITEM	PART NO.	DESCRIPTION	QTY.
Fig. 9-18	1	29896	3/8" TUBE X 1/2" O-RING ELBOW	3
	2	46077	KNOB ONLY	1
	3	46060	HYDRAULIC FLOW CONTROL (NO FITTINGS)	1
	4	45431	CARTRIDGE, FLOW CONTROL (WITH KNOB)	1

Chapter 9 Illustrated Parts List

9.17 Hydraulic Diagram

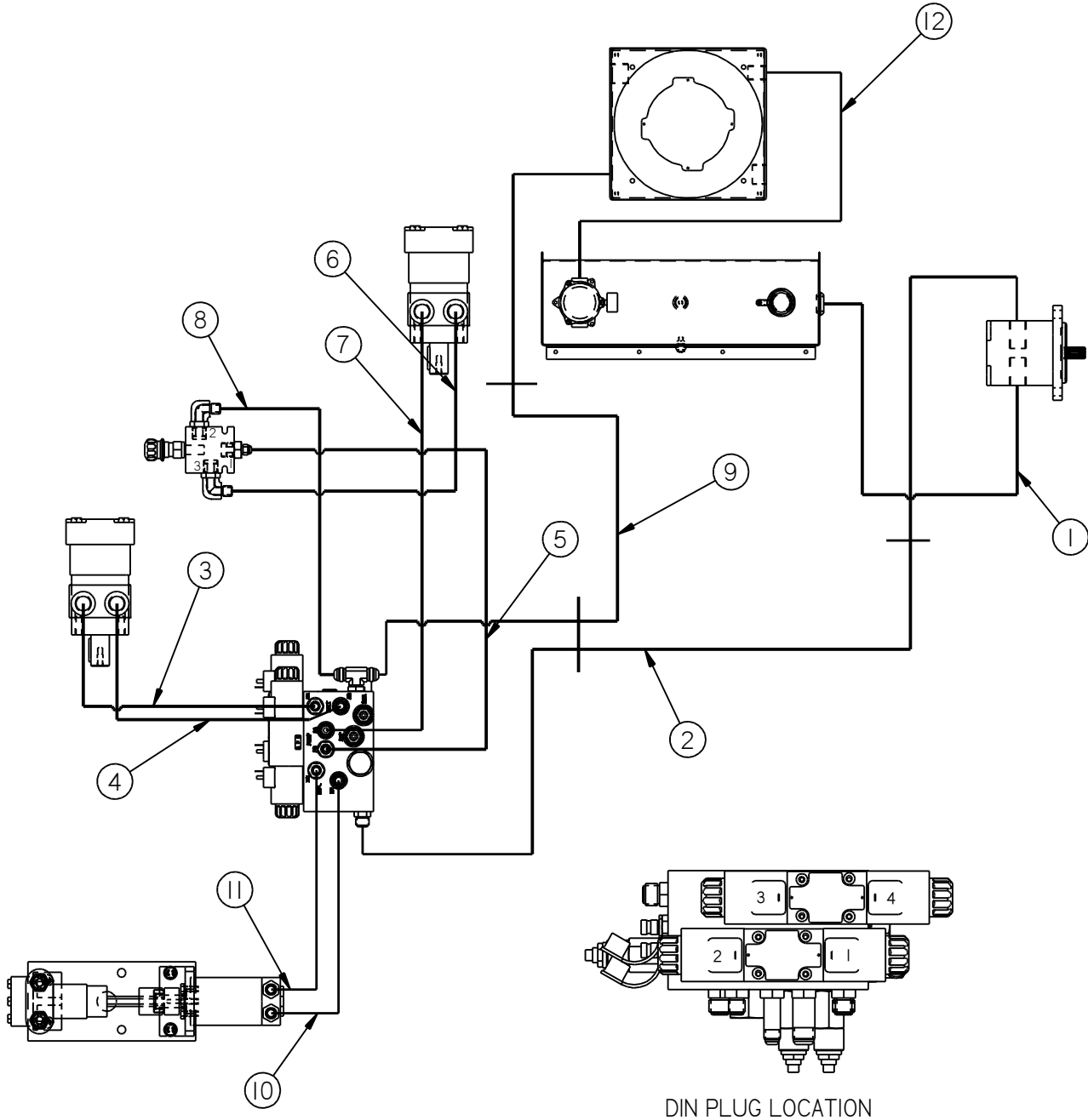

Fig. 9-19 Hydraulic Diagram 46400EB, 46400SB

Chapter 9 Illustrated Parts List

FIG.	ITEM	PART NO.	DESCRIPTION	QTY
Fig. 9-19	1	HYDRAULIC RESERVOIR TO HYDRAULIC PUMP SUCTION PORT		
		29898	FITTING, #20 ORB X #16 JIC 45°	1
		16G4H 16G-16FJX 16G-16FJX45 22	HYDRAULIC HOSE	1
		29820	FITTING, #16 ORB X #16 JIC STR.	1
	2	HYDRAULIC PUMP TO HYDRAULIC VALVE "P" PORT		
		29842	FITTING, #12 ORB X #10 JIC 90°.	1
		8M3K 8G-10FJX 8G-10FJX 24	HYDRAULIC HOSE	1
		29805	FITTING, #10 JIC BULKHEAD	1
		29807	NUT, BULKHEAD FITTING	1
		46433	TUBE, HYDRAULIC PRESSURE	1
		8M3K 8G-8FJX90S 8G-10FJX 31	HYDRAULIC HOSE	1
		29897	FITTING, #12 ORB X #8 JIC STR.	1
	3	HYDRAULIC VALVE "AA" PORT TO AGITATOR MOTOR REAR PORT		
		40311	FITTING, #6 ORB X #6 JIC STR.	1
		6M3K 6G-6FJX 6G-8FJX90S 35	HYDRAULIC HOSE	1
		29808	FITTING, #6 JIC X #6 JIC UNION	1
		46504	TUBE, HYDRAULIC PRESSURE	1
		22029	FITTING, #10 ORB X #6 JIC STR.	1
	4	AGITATOR MOTOR (FRONT PORT) TO HYDRAULIC VALVE "AB" PORT		
		22029	FITTING, #10 ORB X #6 JIC STR.	1
		46503	TUBE, HYDRAULIC RETURN	1
		29808	FITTING, #6 JIC X #6 JIC UNION	1
		6M3K 6G-6FJX 6G-6FJX90S 34	HYDRAULIC HOSE	1
		29919	FITTING, #6 ORB X #8 JIC	1
	5	HYDRAULIC VALVE "PA" TO FLOW CONTROL #1 PORT		
		40308	FITTING, #6 ORB X #6 JIC LONG	1
		6M3K 6G-6FJX90L 6G-8FJX 16	HYDRAULIC HOSE	1
	29896	FITTING, #8 ORB X #8 JIC 90°	1	
6	FLOW CONTROL #3 PORT TO PUMP MOTOR (CURB SIDE PORT)			
	29896	FITTING, #8 ORB X #8 JIC 90°	1	
	8M3K 8G-8FJX90L 8G-8FJX 31	HYDRAULIC HOSE	1	
	29913	FITTING, #10 ORB X #8 JIC STR.	1	

Chapter 9 Illustrated Parts List

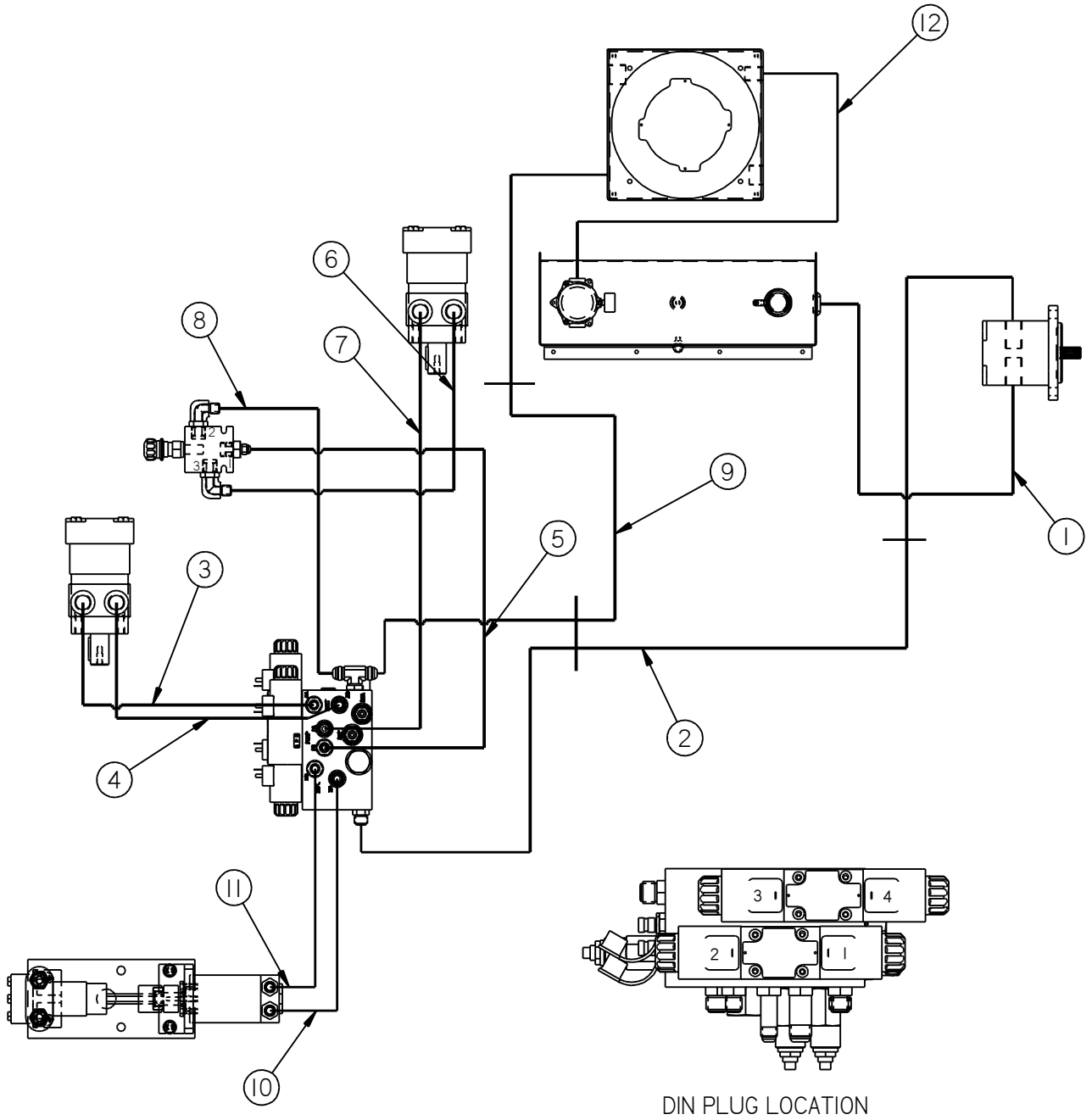

Fig. 9-20 Hydraulic Diagram – 46400EB, 46400SB

Chapter 9 Illustrated Parts List

FIG.	ITEM	PART NO.	DESCRIPTION	QTY.
Fig. 9-20	7	PUMP MOTOR (OVEN SIDE PORT) TO HYDRAULIC VALVE "PB" PORT		
		29913	FITTING, #10 ORB X #8 JIC STR.	1
		8M3K 8G-8FJX 8G-8FJX90S 17	HYDRAULIC HOSE	1
		40320	FITTING, #6 ORB X #8 JIC STR.LONG	1
	8	FLOW CONTROL #2 PORT TO HYDRAULIC VALVE TANK PORT		
		29896	FITTING, #8 ORB X #8 JIC STR.	1
		8M3K 8G-8FJX 8G-8FJX 44	HYDRAULIC HOSE	1
		29976	FITTING, #8 ORB BRANCH TEE	1
	9	HYDRAULIC VALVE TANK PORT TO HYDRAULIC OIL COOLER		
		29976	FITTING, #8 ORB BRANCH TEE	1
		8M3K 8G-8FJX90S 8G-10FJX 27	HYDRAULIC HOSE	1
		29805	FITTING, #10 JIC BULKHEAD	1
		29807	NUT, BULKHEAD FITTING	1
		46432	TUBE, HYDRAULIC RETURN	1
		29805	FITTING, #10 JIC BULKHEAD	1
		29807	NUT, BULKHEAD FITTING	1
		10M3K 10G-10FJX 10G-12FJX 39	HYDRAULIC HOSE	1
		27692	FITTING, #16 FJIC X #12 JIC	1
		29820	FITTING, #16 ORB X #16 JIC STR.	1
	10	HYDRAULIC VALVE (HA PORT)TO HYDRAULIC OIL PUMP		
		29919	FITTING, #6 ORB X #8 JIC	1
		6M3K 6G-6FJX 6G-6FJX90S 20	HYDRAULIC HOSE	1
		40311	FITTING, #6 ORB X #6 JIC	1
	11	HYDRAULIC OIL PUMP TO HYDRAULIC VALVE (HB PORT)		
		40311	FITTING, #6 ORB X #6 JIC	1
		6M3K 6G-6FJX 6G-6FJX90S 22	HYDRAULIC HOSE	1
		40311	FITTING, #6 ORB X #6 JIC	1
	12	HYDRAULIC OIL COOLER TO HYDRAULIC TANK		
		29878	FITTING, #16 ORB X #12 JIC 90°	1
		12M3K 12G-12FJX 12G-12FJX 24	HYDRAULIC HOSE	1
		29991	FITTING, #20 ORB X #12 JIC STR.	1

Chapter 9 Illustrated Parts List

9.18 Electrical Schematic – Electric Hose

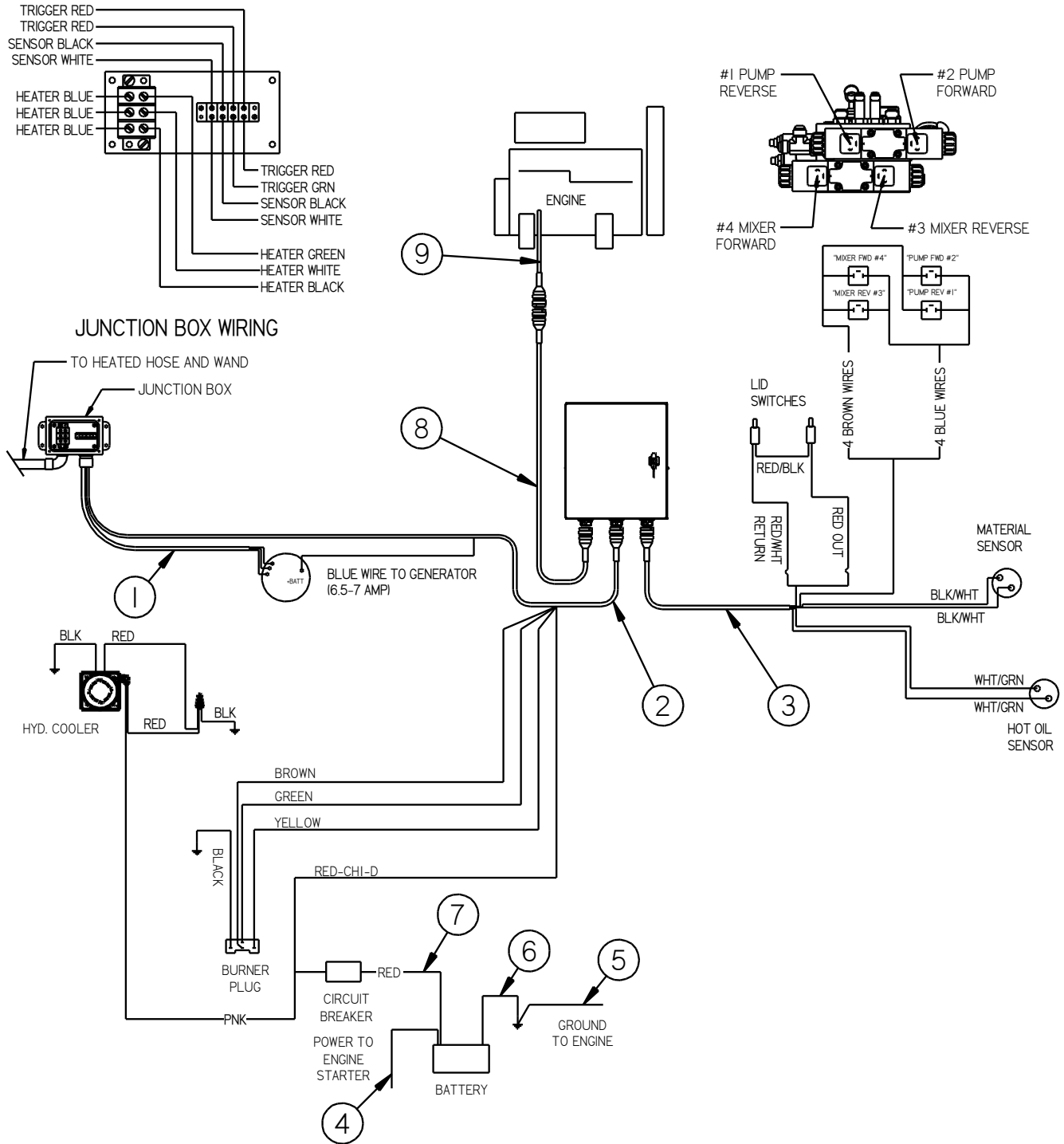

Fig. 9-21 Electrical Schematic 46400EB

Chapter 9 Illustrated Parts List

FIG.	ITEM	PART NO.	DESCRIPTION	QTY.
Fig. 9-21	1	43947	CABLE ASSEMBLY, HOSE	1
	2	38210N	CHASSIS HARNESS	1
	3	38310N	TANK HARNESS	1
	4	24015	POSITIVE BATTERY CABLE, 38"	1
	5	27174	GROUND BATTERY CABLE, BLACK 36"	1
	6	32602	BATTERY CABLE, BLACK, 20"	1
	7	52347N	CIRC BREAKER TO BATTERY WIRE ASSY	1
	8	45970	EXTENSION HARNESS	1
	9	44958B	ENGINE HARNESS, 3CH	1
	NS	38600N	ACTUATOR HARNESS, 3CH, PIGGY BACKS W/44958B	1

Chapter 9 Illustrated Parts List

9.19 Electrical Schematic – Standard Hose

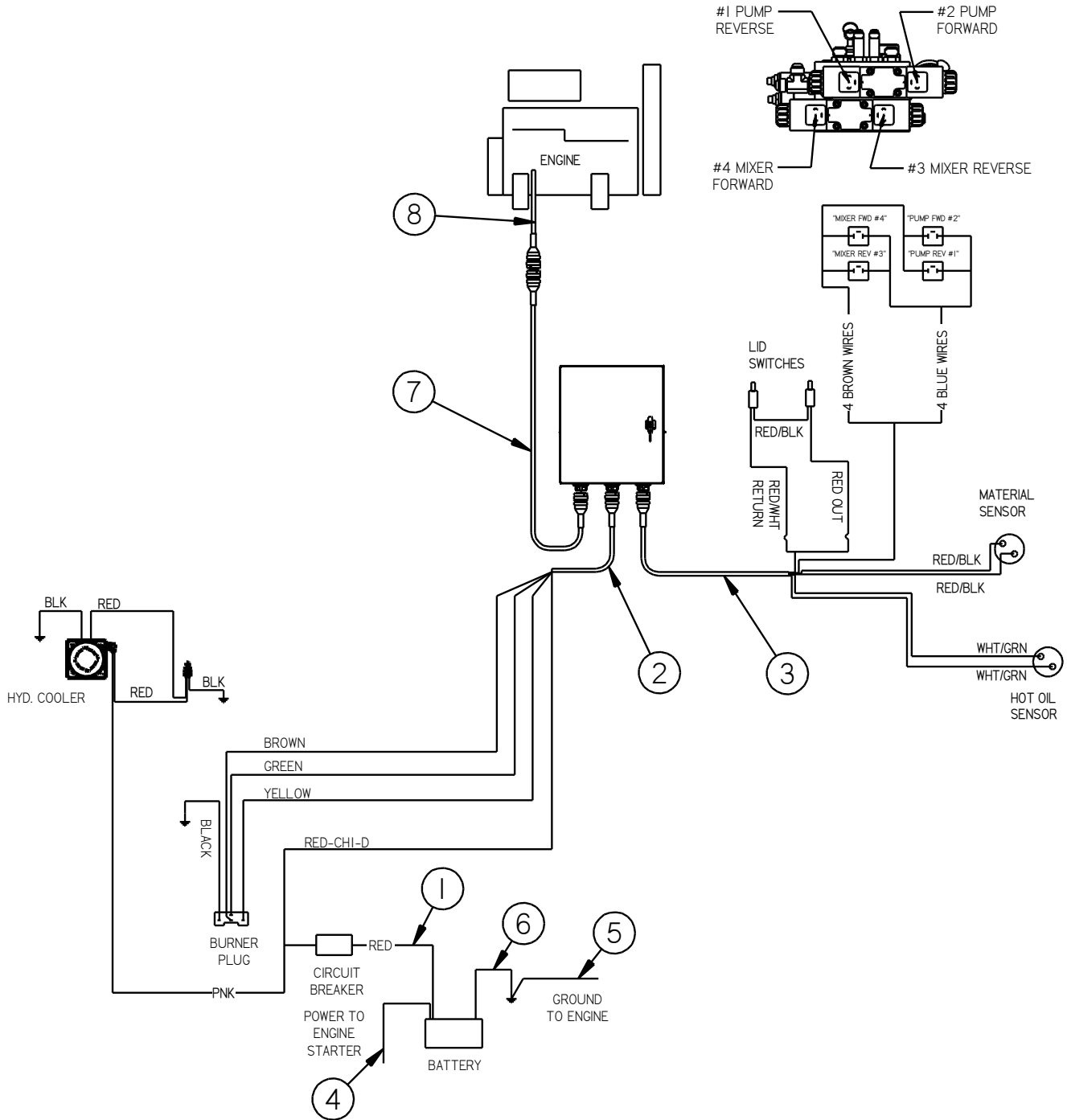

Fig. 9-22 Electrical Schematic 46400SB

Chapter 9 Illustrated Parts List

FIG.	ITEM	PART NO.	DESCRIPTION	QTY.
Fig. 9-22	1	52347N	CIRC BREAKER TO BATTERY WIRE ASSY	1
	2	38211N	CHASSIS HARNESS	1
	3	38310N	TANK HARNESS	1
	4	24015	POSITIVE BATTERY CABLE, 38"	1
	5	27174	GROUND BATTERY CABLE, BLACK 36"	1
	6	32602	BATTERY CABLE, BLACK, 20"	1
	7	45970	EXTENSION HARNESS	1
	8	44958B	ENGINE HARNESS, 3CH	1
	NS	38600N	ACTUATOR HARNESS, 3CH, PIGGY BACKS W/44958B	1

Chapter 9 Illustrated Parts List

9.20 Diesel Fuel Line Schematic

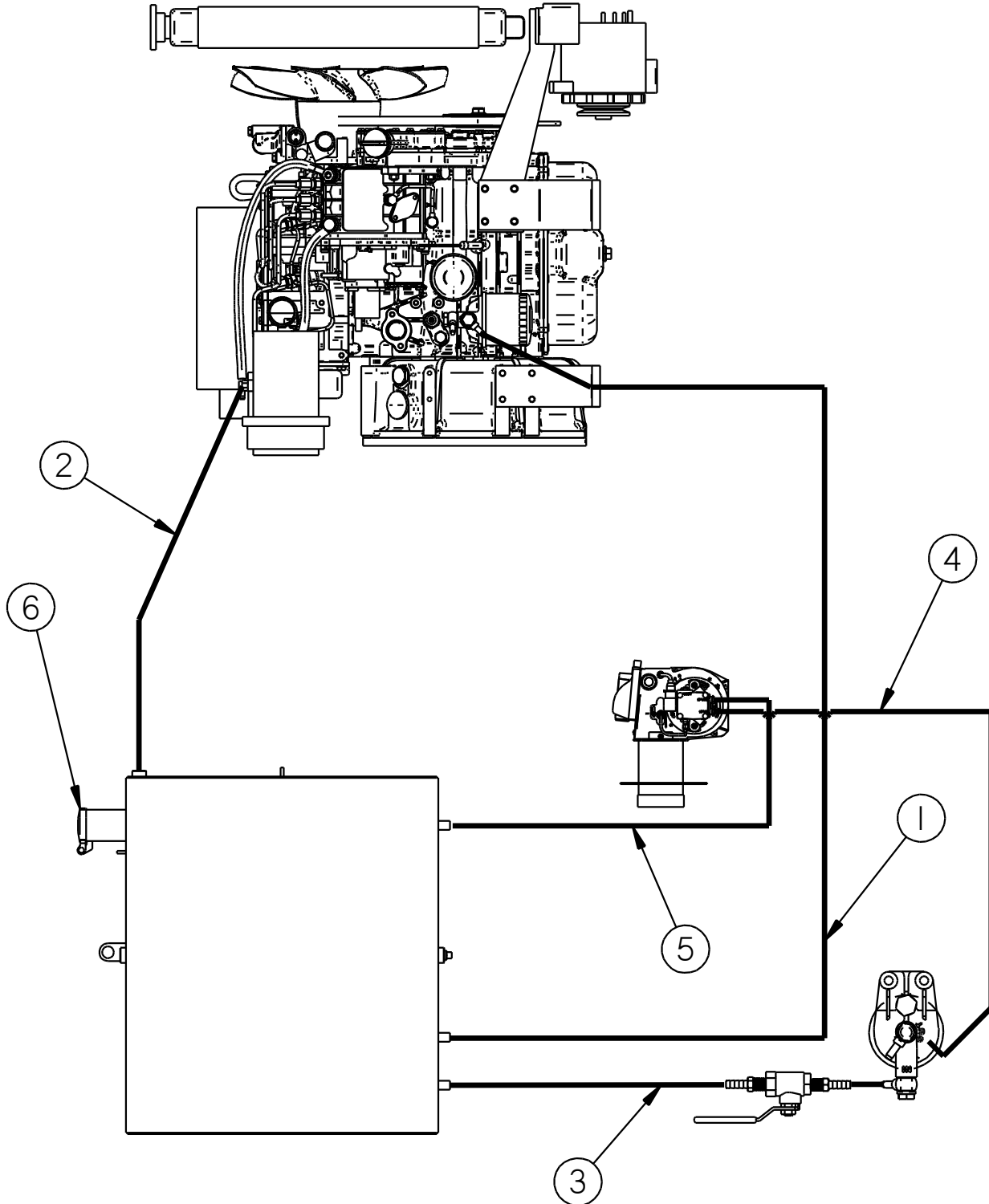

Fig. 9-23 Diesel Fuel Line Schematic

Chapter 9 Illustrated Parts List

FIG.	ITEM	PART NO.	DESCRIPTION	QTY.	
Fig. 9-23	1. DIESEL FUEL TANK TO ENGINE FUEL FILTER "IN" PORT				
		26782	FITTING, 1/4 MPT X 5/16 JIC ELBOW	1	
		26767	FITTING, #5 HOSE PUSH-ON	1	
		29591	HOSE, 5/16 x 95 FUEL LINE	1	
		26080	CLAMP, #4 GEAR	2	
		-	BANJO FITTING	REF.	
	2. ENGINE RETURN LINE TO DIESEL FUEL TANK				
		29602	HOSE, 5/16 X 132 FUEL LINE	1	
		26767	FITTING, #5 HOSE PUSH-ON	1	
		26782	FITTING, 1/4 MPT X 5/16 JIC ELBOW	1	
		26080	CLAMP, #4 GEAR	2	
	3. ENGINE RETURN LINE TO DIESEL FUEL TANK				
		26782	FITTING, 1/4 MPT X 5/16 JIC ELBOW	1	
		26767	FITTING, #5 HOSE PUSH-ON	1	
		47233N	HOSE, 5/16 X 59 FUEL LINE	1	
		29984	HOSE BARB, 1/4 NPT X 5/16 HOSE	1	
		29195	BALL VALVE, 1/4 NPT	1	
		29984	HOSE BARB, 1/4 NPT X 5/16 HOSE	1	
		47234N	HOSE ASSEMBLY, 5/16 X 14	1	
		47345N	FILTER ASSEMBLY	1	
		26080	CLAMP, #4 GEAR	2	
	4. BURNER FUEL FILTER TO BURNER INLET				
		47231N	HOSE ASSEMBLY, 5/16 X 12	1	
		26767	FITTING, #5 HOSE PUSH-ON	1	
		26756N	ADAPTER, 5/16 JIC X 1/4 NPT	1	
		26080	CLAMP, #4 GEAR	2	
	5. BURNER RETURN LINE TO DIESEL TANK				
		26756N	ADAPTER, 5/16 JIC X 1/4 NPT	1	
		26767	FITTING, #5 HOSE PUSH-ON	1	
		47232N	HOSE ASSEMBLY, 5/16 X 65.5	1	
		26767	FITTING, #5 HOSE PUSH-ON	1	
		26782	FITTING, 1/4 MPT X 5/16 JIC ELBOW	1	
		26080	CLAMP, #4 GEAR	2	
	6		43732N	CAP, NON-VENTED DIESEL FUEL	1

Chapter 9 Illustrated Parts List

9.21 High Velocity Heat Lance

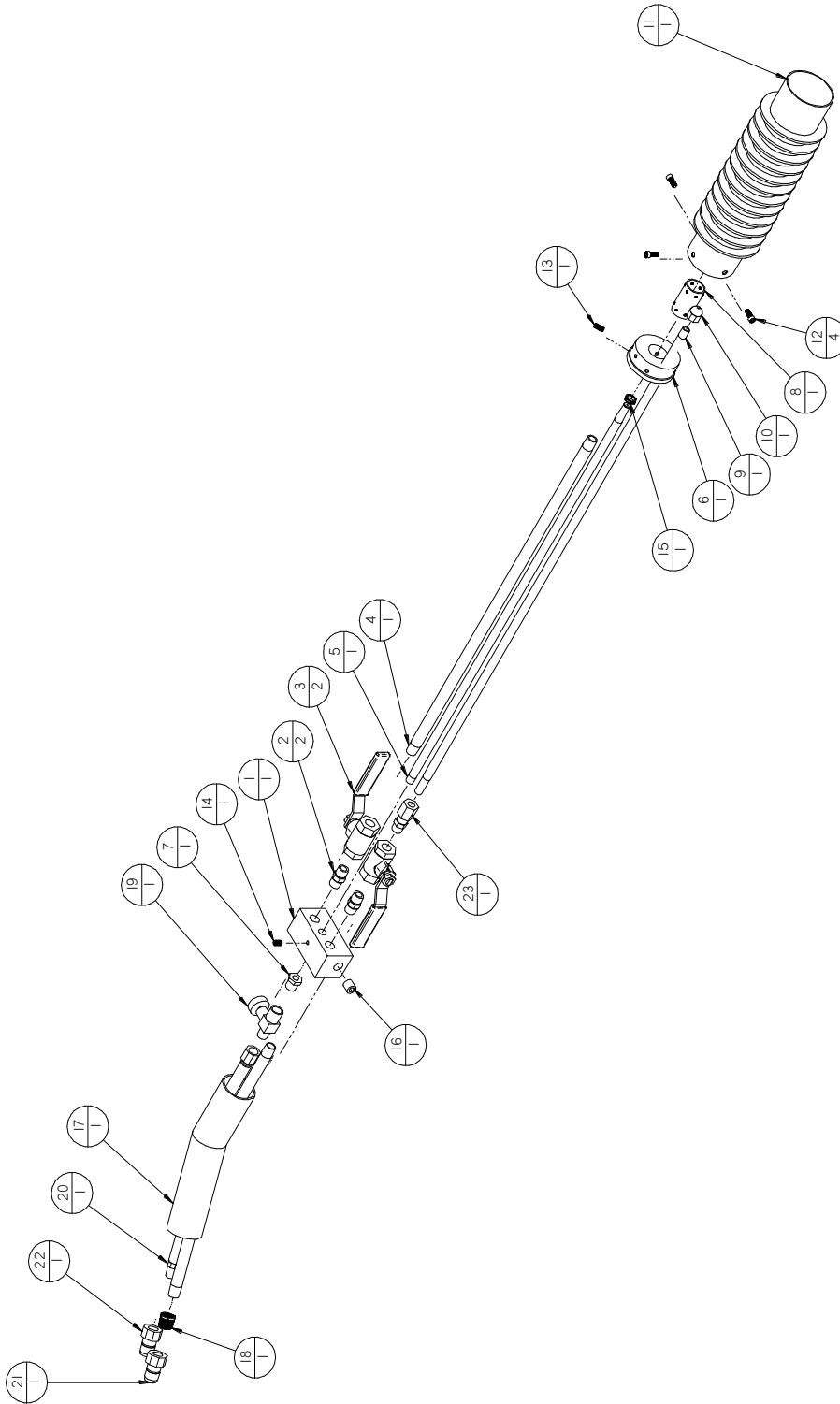

Fig. 9-24 Hot Air Lance (Option)

Chapter 9 Illustrated Parts List

FIG.	ITEM	PART NO.	DESCRIPTION	QTY.
Fig. 9-24	1	45651	MIXING BLOCK	1
	2	51401	NIPPLE, 1/4 NPT HEX	2
	3	29195	VALVE, 1/4" BALL	2
	4	45656	AIR MIXER TUBE	1
	5	45658	PROPANE TUBE W/ ORIFICE	1
	6	45652	BURNER BASE	1
	7	28340	BUSHING, 1/4" NPT X 1/8" NPT	1
	8	45654	PRIMARY BURNER TUBE	1
	9	45657	AIR LANCE TUBE	1
	10	45668	AIR ORIFICE "A" - .125"	1
	11	45653	MAIN BURNER TUBE	1
	12	45670	SCREW, #10-32 X 1/2" ALLEN SCREW	4
	13	45672	SCREW, #10-32 X 1/2" ALLEN SET	1
	14	45671	SCREW, 1/4-20 X 3/8" ALLEN SET	1
	15	45669	NUT, 1/8-27 JAM	1
	16	27990	PLUG, 1/4" COUNTERSUNK	1
	17	45655	HANDLE ASSEMBLY	1
	18	45663	BUSHING, 3/8" NPT X 1/4" NPT REDUCER	1
	19	45659	VALVE, NEEDLE	1
	20	45675	HOSE ASSEMBLY, PROPANE	1
	21	45679	COUPLING, 1/4" FPT X M	1
	22	45681	COUPLING, 1/4" NPT X FM	1
	23	45664	FITTING, 1/4" NPT X 3/8 JIC FERRULE LOCK	1

Chapter 10 Tools and Accessories

10.0 Tools and Accessories



Crafcoco Applicator Disk
27162 – 3" Disk Assembly
27163 – 4" Disk Assembly
27164 – 6" Disk Assembly



Crafcoco Sealing Foot/Protruded
27159 – 1/4" Protruding
27160 – 3/8" Protruding



Crafcoco Joint Sealing Tip
27146 – 1/4" Sealing Tip
27147 – 3/8" Sealing Tip



Crafcoco Swivel Disk Applicator
27120 – 3" Swivel Applicator
27130 – 4" Swivel Applicator



Crafcoco Round Sealing Tip
27170 – 3/8" Sealing Tip
27171 – 1/2" Sealing Tip



Crafcoco Sealing Foot/Flush
27154 – 1/4" Flush
27155 – 3/8" Flush



Crafcoco Cold Air Lance - 42648

Chapter 10 Tools and Accessories



Crafco Heavy Duty Squeegee with Aluminum Handle - 27199
27195 – Replacement Blade



Crafco Pour Pot with Wheels - 40200



Super Shot Drip Stopper
Use with 50270 Duckbill
27114 – Tip Adapter
27115 – Shroud, Tip Adapter



Crafco Hand Held Pour Pot - 40201



Crafco Duckbill - 50270



Crafco High Velocity Heat Lance - 45650

Chapter 10 Tools and Accessories



**Crafc Low Velocity Heat
Lance - 32259**



**Crafc Hand Torch
W/ 20ft. Hose - 25012
W/ 12ft. Hose - 25016
W/ 50ft. Hose - 25021**



©2023 Crafico, Inc.